

# STA-RITE®

## System 3™ Modular Media Filter System

O W N E R ' S M A N U A L

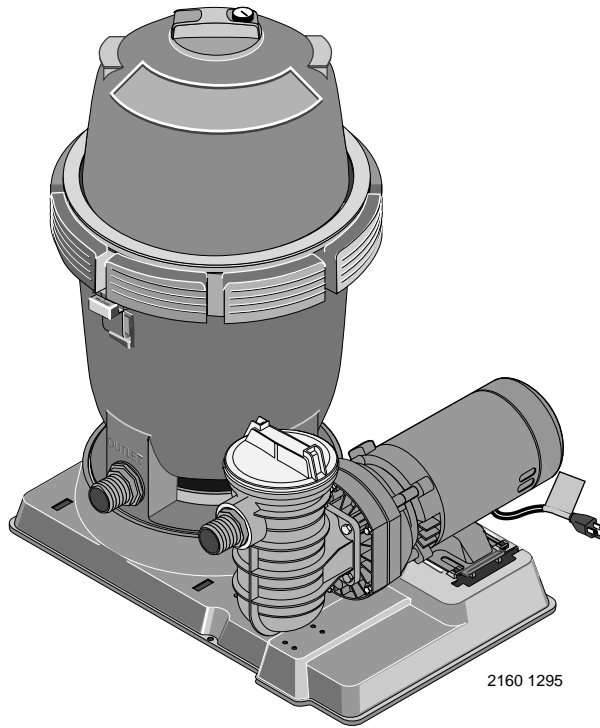

---

INSTALLATION, OPERATION & PARTS

*For Model Numbers and Descriptions See Page 5.*



This manual should be furnished to the end user of this filter; its use will reduce service calls and chance of injury and will lengthen filter life.

### Sta-Rite Pool/Spa Group

293 Wright Street, Delavan, WI 53115

North America: 800-752-0183, FAX 800-582-2217

International: 262-728-5551, FAX: 262-728-4461, TELEX: ITT 4970245

Union City, TN • Delavan, WI • Mississauga, Ont. • Murrieta, CA

U.S. PATENT NO. 5190651 (Other patents pending)

# SYSTEM 3™ MODULAR MEDIA FILTER SYSTEM

To avoid unneeded service calls, prevent possible injuries, and get the most out of your filter system, READ THIS MANUAL CAREFULLY!

The System 3™ Modular Media Filter System Pool Pumps:

- Without a cord or with a 3' cord or no cord are for use with permanently installed pools ONLY (see CAUTION #7, below).
- With a 25' cord are for use with storable pools ONLY (see CAUTION #8, below).

## Table of Contents

Safety Instructions .....	2-3
General Information .....	4
Specifications / Model Numbers and Descriptions.....	5
Installation .....	6
Electrical .....	7
Initial Startup / Operation .....	8
Filter Disassembly / Assembly .....	9-10
Module Cleaning Procedure.....	10
Special Cleaning Instruction.....	10
System Inspection / Winterizing.....	11
Pump Service .....	11-12
Troubleshooting Guide - Pump.....	13
Troubleshooting Guide - Filter .....	14
Repair Parts List.....	15-18
Warranty .....	19

## IMPORTANT SAFETY INSTRUCTIONS

When installing and using electrical equipment, basic safety precautions should always be followed, including the following:

### 1. READ AND FOLLOW ALL SAFETY INSTRUCTIONS.

2. **▲ WARNING** To reduce the risk of injury, do not permit children to use this product unless they are closely supervised at all times.
3. **▲ WARNING** Risk of electrical shock. Connect only to a grounding type receptacle protected by a ground-fault circuit-interrupter (GFCI). Contact a qualified electrician if you cannot verify that the receptacle is protected by a GFCI.
4. Do not bury cord. Locate cord to minimize abuse from lawn mowers, hedge trimmers, and other equipment.
5. **▲ WARNING** To reduce the risk of electrical shock, replace a damaged cord immediately.
6. **▲ WARNING** To reduce the risk of electrical shock, do not use an extension cord to connect unit to electrical supply; provide a properly located outlet.

7. **▲ CAUTION** Permanent pool pumps are for use with permanently installed pools and may also be used with hot tubs and spas if so marked. Do not use with storable pools. A permanently installed pool is constructed in or on the ground or in a building such that it cannot be readily disassembled for storage. A storable pool is constructed so that it may be readily disassembled for storage and reassembled to its original integrity.
8. **▲ CAUTION** Storable pool pumps are for use with storable pools only. Do not use with permanently installed pools. A storable pool is constructed so that it is capable of being readily disassembled for storage and reassembled to its original integrity. A permanently installed pool is constructed in or on the ground, or in a building, such that it cannot be readily disassembled for storage.

## SAVE THESE INSTRUCTIONS

**⚠ WARNING**



**Hazardous Pressure!**  
**Can cause tank explosion.**

Do not connect filter to compressed air under any circumstances.

## READ AND FOLLOW SAFETY INSTRUCTIONS!

**⚠** This is the safety alert symbol. When you see this symbol on your filter or in this manual, look for one of the following signal words and be alert to the potential for personal injury.

**⚠ DANGER** warns about hazards that **will** cause death, serious personal injury, or major property damage if ignored.

**⚠ WARNING** warns about hazards that **can** cause death, serious personal injury, or major property damage if ignored.

**⚠ CAUTION** warns about hazards that **will** or **can** cause minor personal injury or property damage if ignored.

**NOTICE** indicates special instructions not related to hazards.

**Carefully read and follow all safety instructions in this manual and on equipment.** Keep safety labels in good condition; replace if missing or damaged.

**⚠ WARNING** **Hazardous pressure** **Incorrectly installed or tested equipment may fail, causing severe injury or property damage.** Read and follow instructions in owner's manual when installing and operating equipment. Have a trained pool professional perform all pressure tests.

1. Do not connect system to a city water system or other external source of pressurized water.
2. Use equipment only in a pool or spa installation.
3. Trapped air in system can cause explosion. BE SURE all air is out of system before operating or testing equipment.

**Before pressure testing, make the following safety checks:**

- Check all clamps, bolts, lids, lock rings and system accessories before testing.
- Release all air in system before testing.
- Tighten Sta-Rite trap lids to 30 ft. lbs. (4.1 kg-cm) torque for testing.
- Water pressure for test must be less than 25 PSI (172 kPa).
- Water Temperature for test must be less than 100° F. (38° C).
- Limit test to 24 hours. After test, visually check system to be sure it is ready for operation. Remove trap lid and retighten hand tight only.

**NOTICE:** These parameters apply to Sta-Rite equipment only. For non-Sta-Rite equipment, consult equipment manufacturer.

## GENERAL INFORMATION

- Clean a new pool as well as possible before filling pool and operating filter. Excess dirt and large particles of foreign matter in the system can cause serious damage to the filter and pump.
- With a modular media filter system in place and operating correctly, clean water is returned to the pool faster than pool water is being contaminated. A typical pool installation will require approximately one week to obtain and maintain the sparkle that your filter is capable of giving you.
- Maximum pressure is 50 PSI (345 kPa). DO NOT connect the filter to a city water system.

**⚠ WARNING** Hazardous pressure. Open air release valve to vent all air from system before operating system. NEVER operate filter with air trapped inside.

- The Sta-Rite modular media filter system is designed to filter water for swimming pools and spas. On a new installation, we recommend:
  1. Disassemble the filter after the initial cleanup.

**⚠ WARNING** Hazardous pressure. To prevent severe injury or major property damage, exactly follow "Filter Disassembly/Assembly Procedure" on Pages 8 and 9.

2. Remove and hose down the filter module to remove contaminants.

- Maintain pool water pH between 7.2 and 7.6.
- Make sure that internal air bleed tube and filter are clean and installed properly at top of module before operating filter.
- Make sure that Posi-Lok™ Ring is securely locked in place before operating filter.
- Maintain pressure gauge in good working order. Replace a damaged gauge immediately.
- Cleaning interval is based on pressure rise, not on length of time filter is operated. Different water conditions will have different normal cleaning intervals.
- Check local codes for restrictions on waste water disposal requirements.

**NOTICE:** Some pool disinfectants may clog filter module. To maximize module life and filter cycle time, closely follow disinfectant manufacturer's instructions when cleaning pool or filter. Failure to follow these instructions may affect warranty coverage of the module.

### Owner's Information

Serial Number \_\_\_\_\_

Dealer \_\_\_\_\_

Dealer's Telephone # \_\_\_\_\_

Purchase Date \_\_\_\_\_

Installation Date \_\_\_\_\_

Pressure Gauge Reading at Startup \_\_\_\_\_

### When to Clean the Filter

The filter module should normally be cleaned when the pressure gauge reading increases 10 PSI over the start-up pressure (record the start-up pressure under "Owner's Information", below, right).

In some pools, accessories such as fountains or pool cleaners may be noticeably affected by the normal decrease in flow as the filter becomes dirty. If so, clean the filter more frequently (that is, at a pressure increase of less than 10 PSI) in order to maintain the required flow.

**⚠ WARNING**



**Risk of falls and injury.**

**Filter surface is slippery.**

Do not allow children to stand or play on filter.

# SPECIFICATIONS / MODEL DESCRIPTIONS

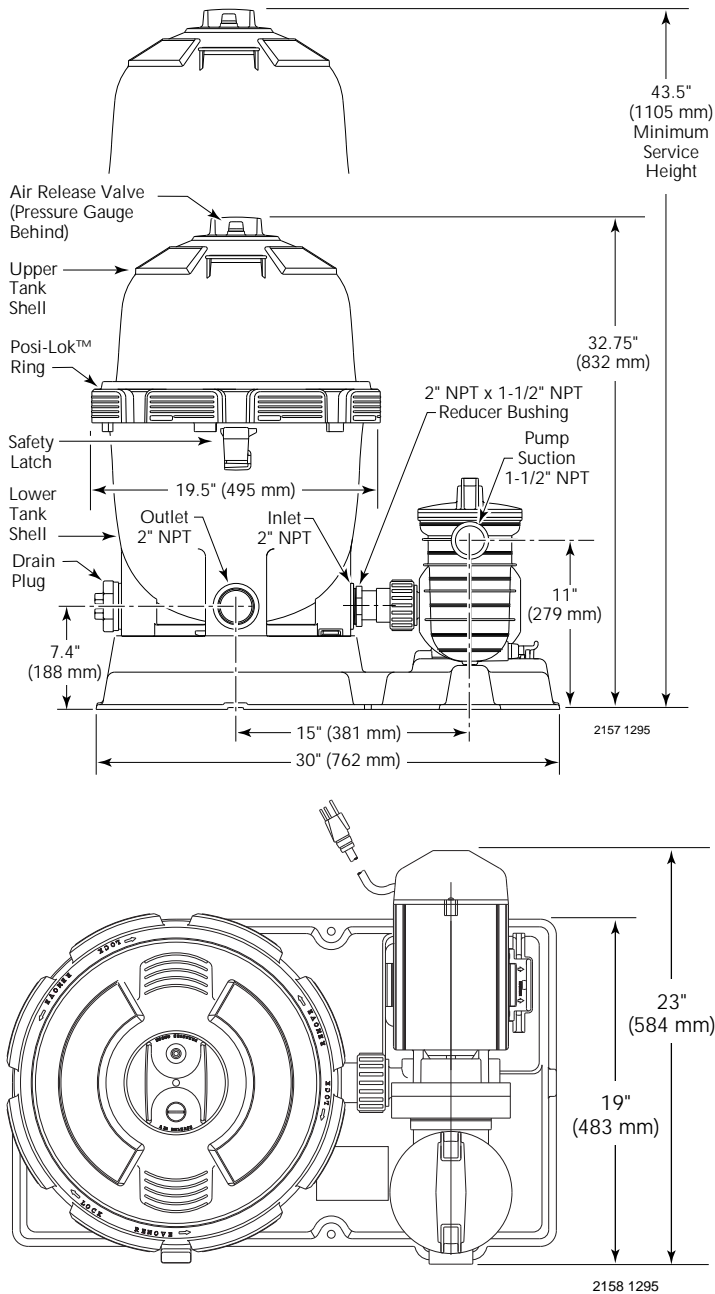

FIGURE 1 – Dimensions in inches (mm)

Table 1 - Filter Specifications

	Model No.	
	PLM100	PLM150
Filter Area sq. ft. (m <sup>2</sup> )	100(9.3)	150(14)
Max. Rated Flow GPM (LPM)*		
Residential	100(379)	150(568)
Commercial	37(140)	56(212)
Max. Operating Pressure PSI (kPa)	50(345)	50(345)
Max. Continuous Water Temperature F(C)	104°(40°)	104°(40°)

\* For best water clarity and filter cycle length, restrict water flow to 50 GPM (189 LPM).

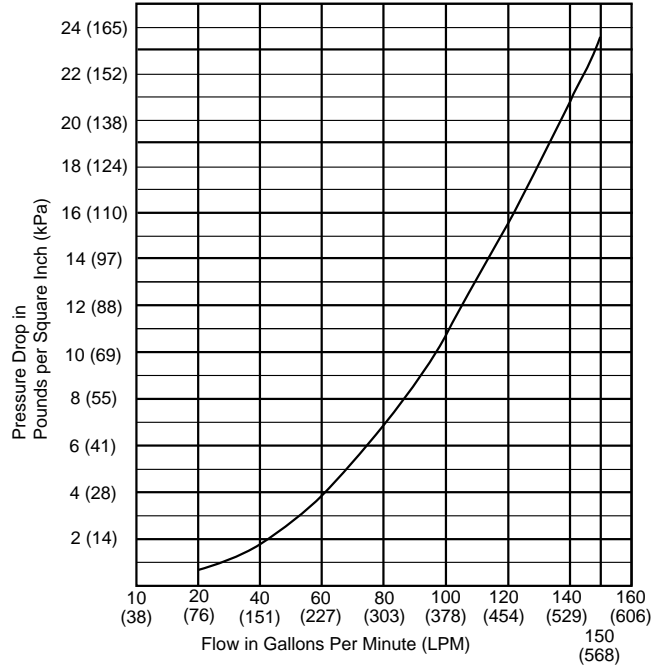

FIGURE 2 – Pressure Drop Curve

## Model Descriptions

**PLM100JWAE-03 PLM100JWAF-03**  
**PLM150JWAE-03 PLM150JWAF-03**  
 Hoses, Adapters, Clamps, and U.S.A. Spec. Motor  
 (Includes 3' Cord w/Straight Plug)

**PLM100JWAE-06 PLM100JWAF-06**  
**PLM150JWAE-06 PLM150JWAF-06**  
 Adapters, Clamps, and Canadian Spec. Motor  
 (Includes 25' Cord w/Straight Plug)

**PLM100JWAE-04 PLM100JWAF-04**  
**PLM150JWAE-04 PLM150JWAF-04**  
 Adapters, Clamps, and U.S.A. Spec. Motor  
 (Includes 3' Cord w/Straight Plug)

**PLM100JWAE-12 PLM100JWAF-12**  
**PLM150JWAE-12 PLM150JWAF-12**  
 Adapters, Clamps, and U.S.A. Spec. Motor  
 (Includes 3' Cord w/Twist-Lok Plug)

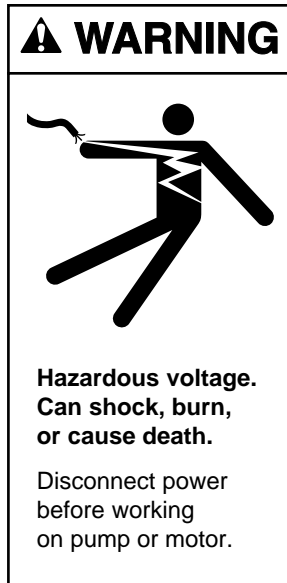

**NOTICE**  
Make sure that the filter and all piping can be drained for winterizing. See "Winterizing", Page 10.

## INSTALLATION

Installation of filter should only be done by qualified, licensed personnel.

### Assembly:

- Unpack filter system and check it for transit damage.
- Open the accessory package and install the pressure gauge (with the filter screen under it; see exploded view, Page 15) in the open port on top of the filter tank. Do not overtighten.
- Install hoses with adapters and clamps provided in the accessory package. Run one line from the skimmer to the pump suction port. Run the other line from the filter outlet to the pool inlet fitting.

### Filter mount must:

- Provide weather and freezing protection.
- Provide adequate ventilation and drainage for pump.
- Provide space and lighting for easy access for routine maintenance. (See Figure 1 for space requirements.)
- Be installed with the trap suction inlet below the pool water level at all times (to allow the pump to prime).
- Be on a reasonably level surface and provide adequate drainage.

### Piping:

- Piping must conform to local/state plumbing and sanitary codes.
- Use teflon tape, Plasto-Joint Stik<sup>®1</sup>, or Silastic RTV #732<sup>®</sup> on all male connections of plastic pipe and fittings. **DO NOT use pipe compounds on plastic pipe; it will cause the pipe to crack. Do not use sealant on unions – assemble them dry and hand tight.**
- Support pipe independently to prevent strains on filter or pump.
- Fittings restrict flow; for best efficiency use fewest possible fittings.
- For ease of maintenance, use Sta-Rite union couplings to connect the piping to the filter inlet and outlet ports.
- Keep piping tight and free of leaks: pump suction line leaks may cause trapped air in filter tank or loss of prime at pump; pump discharge line leaks may show up as dampness or jets of water.
- **NOTICE:** Overtightening can crack filter ports.

### Valves:

- Install valves on both sides of the filter to isolate filter for easy servicing.  
**NOTICE:** Install heater downstream of filter. If heater does not incorporate a check valve, install one at the heater inlet to prevent hot water from backing up into the filter. Filter modules damaged by excessive heat will void the warranty.
- A check valve installed ahead of filter inlet will prevent contaminants from draining back into pool.

<sup>1</sup> Lake Chemical Co., Chicago, IL

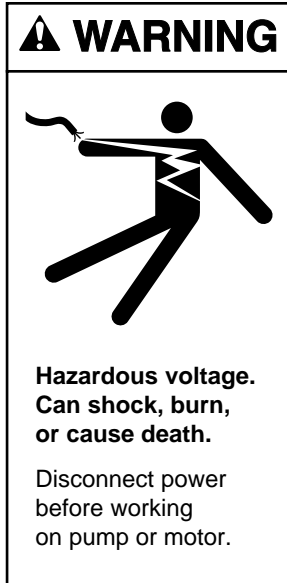

## ELECTRICAL

- ⚠ Risk of electrical shock. Plug pump into a grounded, GFCI-protected 115 Volt circuit only. Incorrect voltage can cause fire or seriously damage motor and voids warranty. Protect cord from water and physical damage.
- ⚠ GFCI tripping indicates an electrical problem. If GFCI trips and will not reset, have a qualified electrician inspect and repair electrical system.

**WARNING** Risk of electrical shock. Unplug motor before servicing or repairing pump or motor.

### Wiring:

Install a Ground Fault Circuit Interrupter (GFCI) in circuit; it will sense a short circuit to ground and disconnect power before it becomes dangerous to pool or spa users. For size of GFCI required and test procedures for GFCI, see manufacturer's instructions.

In case of power outage, check GFCI for tripping (which will prevent normal water circulation); reset if necessary.

Do not connect any other lights or appliances to the same circuit.

Match circuit breaker size to Table II below.

- Do not modify cord, plug, or receptacle. If an existing circuit must be used and the receptacle and plug do not match exactly, consult a licensed electrician.
- Do not use an extension or drop cord with this system; it could cause a fire hazard or low voltage problems. Wet cords cause shock hazards. Extension cords can easily become cut or frayed and dangerous when placed across yard areas or walkways.

### Voltage:

Voltage at motor must be not more than 10% above or below motor nameplate rated voltage or motor may overheat, causing overload tripping and reduced component life. If voltage is less than 90% or more than 110% of rated voltage when motor is running at full load, consult power company.

**Table II—Recommended Fusing Data, 115 Volt 60 Hz Motors.**

Model No.	Motor H.P.	Max Load Amps	Branch Circuit Breaker Rating (Amps)
JWPA5E7L-2A1, -2A2	1	12.0	15
JWPA5E7C-2A3, 2A3U	1	11.9	15
JWPA5F7L-2A1, -2A2, -A1	1-1/2	16.0	20
JWPS5F7C-2A3, 2A3U	1-1/2SPL	11.9	15

**NOTICE** Values given are for pump motor only. Do not put any other accessories on this circuit.

1 HP Filter system with Model No. suffix: -03, -04, or -06

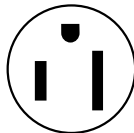

1 HP Pumps with -2A2 suffix and Canadian Spec Pumps use 15-amp straight outlet, above.

1-1/2 HP Filter system with Model No. suffix: -03, -04, or -06

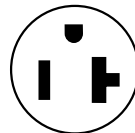

1-1/2 HP Pumps with -2A2 suffix use 20 amp straight outlet, above.

All Filter systems with Model No. suffix: -12 or -15

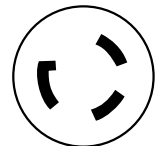

All Pumps with -2A1 suffix use 20-amp twist-lock outlet, above.

**FIGURE 3 - Plug configurations**

**⚠ WARNING**



**Hazardous pressure. Can cause severe injury or major property damage from tank blow up.**

Release all pressure and read instructions before working on filter.

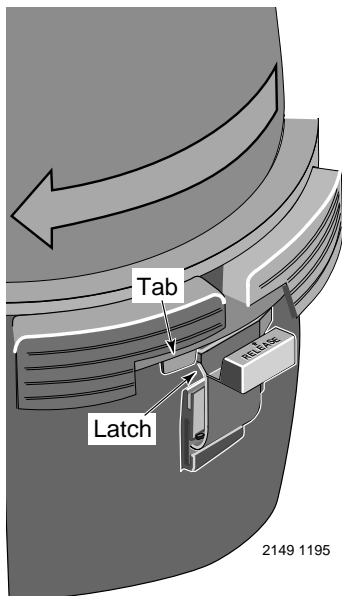

**Figure 4 – Rotate Posi-Lok™ Ring until tab locks behind the safety latch.**

## INITIAL START-UP

**⚠ DANGER** Hazardous suction. Pump suction can trap or tear body parts, especially with children. Do not block suction. Small children using pool must ALWAYS have close adult supervision!

**⚠** Do not operate system with water temperature above 104° F (40° C).

**⚠ CAUTION** NEVER run pump dry. Running pump dry may damage seals, causing leakage and flooding. Fill pump with water through the hair and lint strainer lid before starting the pump.

**⚠ WARNING** Do not add chemicals to pool directly in the pool skimmer. Adding undiluted chemicals may damage pump and void warranty.

**⚠** Be sure pump is OFF before starting procedure.

**⚠** Do not operate these filters at more than 50 PSI (345 kPa) under any circumstances!

1. Securely lock Posi-Lok™ ring in place by rotating ring CLOCKWISE until it “clicks” past the safety latch (see Figure 4). Stop turning as soon as the ring clicks past the latch. The ring may feel slightly loose, but it will tighten up when pump is on and filter is under pressure.
2. Fill trap on pump with water.
3. Open air release valve on top of filter.
4. Open isolation valves.
5. Start pump to purge air from system.
6. When steady stream of water comes from air release valve, close the valve.

**NOTICE:** Leaking around the Posi-Lok™ ring may indicate that the ring is not fully locked. In this case, proceed as follows:

- A. Stop the pump, close the isolation valves, and open the air release valve to release any pressure within the filter.
- B. Remove the drain plug and drain all water from the filter.
- C. Push down on the top of the filter to fully seat the upper tank shell.
- D. Rotate the Posi-Lok™ clockwise until it locks behind the safety latch (see Figure 4).
- E. If the ring was already locked, remove it and the upper tank shell. Inspect and clean the O-ring and all sealing surfaces. Relubricate the O-ring.

**NOTICE:** Lubricate O-ring only with the silicone grease provided or equivalent, as other lubricants may cause the ring to swell. DO NOT lubricate Posi-Lok™ ring or threads on lower tank shell as this may collect grit and make removal difficult.

After filter is operating, record filter pressure gauge reading in owner's manual for future use.

**NOTICE:** When installed on a new pool, after approximately 48 hours of operation disassemble filter and clean out plaster dust, construction debris, etc. (see “Module Cleaning Procedure”, Page 9).

## OPERATION

### Priming Pump:

Fill pump with water through hair and lint strainer lid opening.

Open suction and discharge valves before starting system.

Make sure that pool water is 2" - 3" (51mm - 76mm) above bottom of skimmer opening and/or other suction outlets.

### Water Maintenance:

Keep water level at least two inches (51mm) above bottom of skimmer opening when system is not in use. Failure to do so can allow air to enter system, causing pump to lose prime and filter to entrap air.

Maintain pH at 7.2 to 7.6 in pool.

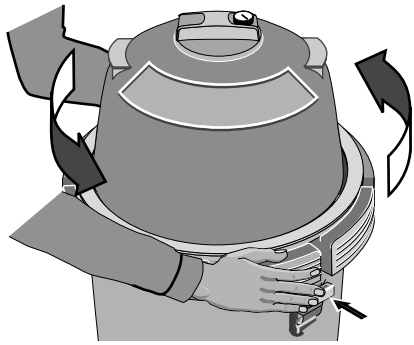

Figure 5 – Depress safety latch to unscrew Posi-Lok™ Ring.



Figure 6 – Insert ring tab in slot in filter body.

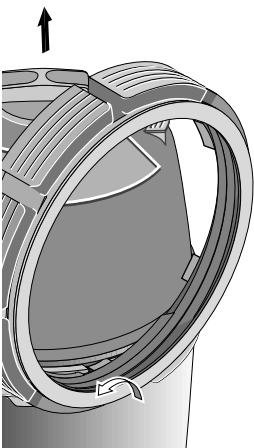

Figure 7 – Roll ring to one side to loosen upper tank half.

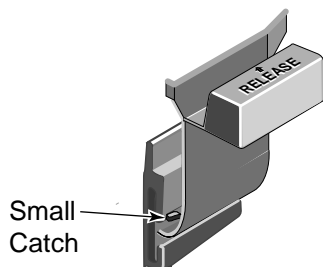

Figure 8 – Safety Latch

## FILTER DISASSEMBLY/ ASSEMBLY PROCEDURE

**▲ WARNING** Hazardous pressure. Before disassembling filter:

1. STOP PUMP.
2. CLOSE isolation valves.
3. OPEN air release valve and drain fitting.
4. WAIT until all pressure is released and water drained from filter tank and system before loosening Posi-Lok™ Ring.

### Disassembly:

1. Stop the pump.
2. Close isolation valves to prevent flooding.
3. Open air release valve on top of filter tank to release all pressure from inside of tank.

**NOTICE:** Make sure that waste water disposal complies with local codes and ordinances.

4. Remove drain plug and drain all water from tank.
5. Remove Posi-Lok™ ring as follows:
  - a. Press safety latch (below the ring) toward the tank to release it (see Figure 5).
  - b. Hold latch in the release position and rotate ring COUNTERCLOCKWISE to remove. If ring is difficult to turn, tap gently with a rubber mallet to overcome initial resistance.

**NOTICE:** DO NOT use screwdriver or bladed instrument that may damage shell surfaces to pry tank shells apart.

6. Separate upper and lower tank shell halves using tabs on bottom of Posi-Lok™ ring. Insert tab into slot located at tank joint and twist ring to pry shell halves apart. See Figures 6 and 7.
7. Remove O-ring from upper tank shell. Inspect for cuts, cracking, deformation or signs of wear; replace if necessary.

**NOTICE:** To avoid strain or damage, allow filter module to drain before lifting it out of the tank.

### SAFETY LATCH (See Figure 8)

The purpose of the safety latch is to hold the Posi-Lok™ ring in the locked position. If the latch is damaged, replace it as follows:

1. Press down on the small catch behind the safety latch and press or tap the latch out of the "Tee" slot in the tank (see Figure 8).
2. Snap the new latch into position.

**NOTICE:** DO NOT operate the filter if the safety latch is damaged or will not hold the Posi-Lok™ ring in the locked position.

### Assembly:

1. Inspect and clean the tank, ring threads and O-ring groove. Replace damaged parts as necessary.
2. Install the filter by placing the port in the bottom of the filter cartridge over the tank outlet port. Push down firmly to seal.
3. Ensure that the air bleed assembly on top of the module is clean and properly mounted.

**NOTICE:** Lubricate O-ring only with the silicone grease provided or equivalent, as other lubricants may cause the ring to swell. DO NOT lubricate Posi-Lok™ ring or threads on lower tank shell as this may collect grit and make removal difficult.

### When to Clean the Filter

The filter module should normally be cleaned when the pressure gauge reading increases 10 PSI over the start-up pressure (record the start-up pressure under "Owner's Information", Page 3).

In some pools, accessories such as fountains or pool cleaners may be noticeably affected by the normal decrease in flow as the filter becomes dirty. If so, clean the filter more frequently (that is, at a pressure increase of less than 10 PSI) in order to maintain the required flow.

### Recommended Specialty Filter Cleaners

Filter Cleanse™,  
Great Lakes Biochemical

BIOGUARD Strip Kwik™,  
BIOGUARD KleenIt™,  
Softswim® Filter Cleaner,\*\*  
BIOLABS, Inc.

Filter Kleen™,  
Haviland Products Co.

BAQUA CLEAN™, \*\*  
Zeneca, Inc.

\*\* MUST be used when using any PHMB based sanitizer.

4. Install the O-ring in the upper tank shell O-ring groove. Be sure that the O-ring is clean and not twisted.
5. Push the upper tank shell into the lower tank shell to compress the O-ring.
6. Place the Posi-Lok™ ring squarely over the tank shell threads and rotate COUNTERCLOCKWISE until the ring falls into the slots; then rotate CLOCKWISE until securely latched.
7. Follow instructions in the "Initial Startup" section of this manual.

## MODULE CLEANING PROCEDURE

Follow all steps in the "Disassembly" section of this manual.

The filter module should be removed and cleaned when pressure rises more than 10 psi (69 kPa) above startup pressure. See also "When to Clean the Filter," at left.

**⚠ WARNING** Risk of chemical burns. Do not attempt to acid clean the filter or module. If the filter requires acid cleaning, have a trained pool professional do the job.

**NOTICE:** When sanitizing your pool using PHMB (polyhexamethylene bi-quanide based) cleaners, use *only* PHMB cleaners to clean the module. When using PHMB sanitizers, the filter module MUST be cleaned more thoroughly and frequently than for a pool using chlorine. Follow manufacturer's instructions carefully. Use of any other type of cleansers with PHMB pool sanitizers will void the filter's warranty.

**NOTICE:** Avoid washing filter debris into the outlet port. Remove drain plug and flush foreign material from inside of tank before removing filter module.

1. With a hose equipped with a soft flow nozzle, wash as much dirt as possible off of the filter module while it is still inside the tank. Allow tank to drain completely.
2. Make sure that the inside of the tank is clean. Lift out the module and hose it down thoroughly. Spray the entire module surface. Allow module to drain.
3. Inspect the module. If necessary, repeat the washing operation. If the module is damaged, replace it.

**NOTICE:** If this cleaning method does not remove all deposits, see "Special Cleaning Instructions" section in this manual.

4. Inspect and clean air bleed filter at top of module.
5. Follow all steps in the "Assembly" and "Initial Startup" sections of this manual.

### Special Cleaning Instructions:

Use this procedure to clean scale or oils which are not removed by hosing down module. Be sure to dispose of spent chemicals according to all applicable codes and waste disposal ordinances. Use a soft stream nozzle to minimize flying water and spray.

**⚠ DANGER** Risk of fire or explosion. Isolate filter from system before chemical cleaning; rinse filter and elements completely before returning to service. If filter cannot be isolated, remove media and clean at another location. Follow chemical manufacturer's instructions for use. Do not mix chemicals except as directed by manufacturer. Do not allow cleaning chemicals to mix with or to come in contact with chlorine, bromines, other chemicals, or chemical feed devices.

1. Sponge or spray the module according to chemical manufacturer's directions.
2. If soaking is required, remove the module from the filter tank and submerge it in a separate tank. Follow cleaner manufacturer's instructions carefully.
3. After completing chemical manufacturer's instructions, drain and rinse the module completely. Dispose of cleaners in accordance with local codes and disposal ordinances.
4. Rinse the inside of the filter tank. Drain it completely.
5. Follow instructions in the "Assembly" and "Initial Startup" sections of this manual.

## SYSTEM INSPECTION

### General:

Wash the outside of the filter with a mild detergent and water. Rinse off with a hose.

**NOTICE:** DO NOT use solvents to clean the filter; solvents may damage plastic components in the system.

**NOTICE:** Open the air bleed valve and bleed all air from the filter each time the pump is stopped and restarted.

### Weekly Inspection:

1. Remove debris from the pool skimmer basket.
2. Stop the pump; open the air release valve to release all pressure.
3. Remove the trap cover and basket; remove debris.
4. Check the pump for leaks. If found, see the pump owner's manual.
5. Replace the trap basket and the cover. Tighten the cover securely hand tight. DO NOT use a lid wrench to tighten it.
6. Start the pump. When the filter air release valve runs a solid stream of water, close the valve.
7. When the system has returned to normal operation, check the filter pressure. If the filter pressure is 10 PSI (69kPa) or more higher than the initial startup pressure, the filter needs cleaning. See "Module Cleaning Procedure", Page 9.

## WINTERIZING

**⚠ WARNING** Explosion hazard. Purging the system with compressed air can cause components to explode, with risk of severe injury or death to anyone nearby. Use only a low pressure (below 5 PSI), high volume blower when air purging the pump, filter, or piping.

**NOTICE:** Protect the filter from freezing. Allowing the filter to freeze will damage it and will void the warranty.

1. Clean the filter according to instructions (Page 9) before winterizing.
2. Stop the pump.
3. Open the air release valve; open all the system valves.
4. Remove the drain plugs from the trap, pump, and filter.
5. Drain the system piping.
  - A. Gravity drain system as far as possible.
  - B. Protect areas which retain water with non-toxic propylene glycol antifreeze ("RV antifreeze").
6. Loosen the union nuts (if used) to drain all water from the filter interior. Leave these nuts loose until the system is restarted.
7. Disassemble the filter (follow instructions under "Filter Disassembly", Pages 8 and 9). Remove the filter module and store it in a warm, dry area.
8. If the filter is equipped with an optional internal spring check valve (in the tank outlet), manually open the check valve to allow any water trapped in the tank to drain.
9. Cover the filter with plastic or tarpaulin to prevent water entrance and freezing.

## PUMP SERVICE

Pump should only be serviced by qualified personnel.

**⚠** For continued protection against possible electric shock, use only identical replacement parts when servicing.

**⚠** Before removing trap cover:

1. STOP PUMP before proceeding.

### NOTICE

The filter outlet piping will not empty through the filter drain. Make sure that the outlet piping has a separate drain for winterizing.



Figure 9



Figure 10



Figure 11



Figure 12

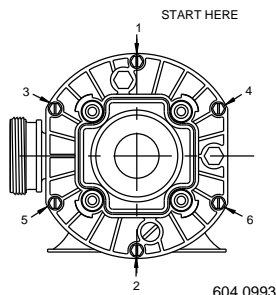

Figure 13 - Torque Sequence

2. CLOSE GATE VALVES in suction and discharge pipes.
3. RELEASE ALL PRESSURE from pump and piping system.

**⚠ To avoid dangerous or fatal electrical shock hazard, turn OFF power to motor before working on pump or motor.**

No lubrication or regular maintenance is needed beyond reasonable care and periodic cleaning of strainer basket. Trap cover O-Ring is internally lubricated and needs no additional lubrication.

If shaft seal is worn or damaged, repair as follows:

### Pump Disassembly:

1. Unplug motor before servicing or repairing pump or motor.
2. Close all valves in suction and discharge piping.
3. Remove drain plugs from the bottom of pump and trap; drain pump completely.
4. Disconnect pipe unions (or clamps) on suction and discharge piping. Remove hold down bolts and withdraw complete pump/motor/trap assembly.
5. Remove cap screws (Key No. 16, Pages 16 and 17) from front plate (Key No. 13). Remove front plate with trap (Key No. 20) attached. Remove and inspect O-Ring (Key No. 12).
6. Remove end cap (Key No. 2) from motor.
7. Hold motor shaft with 7/16" wrench on flats on motor shaft; unscrew impeller (Key No. 11).
8. Carefully remove rotating half of seal (Key No. 10) from impeller sleeve. Twist as you pull; make sure you do not damage surface of sleeve where seal both seats and seals. See Figure 9.
9. Remove motor throughbolts (see Figure 10). Remove seal plate (Key No. 9). Tap stationary half of seal out of seal plate (see Figure 11).
10. If necessary, disconnect electrical wiring from motor terminal board and remove motor (Key No. 6) from motor cover (Key No. 8; -06 models only).

### Pump Assembly:

1. Examine seal cup and O-Rings. Replace anything that shows signs of wear or damage.
2. Check the shaft seal (Key No. 10) for scoring, scratches, chips, etc., and for any signs of damage to spring or retainer. Replace if any wear or damage is visible.
3. Press stationary half of seal into seal plate (Key No. 9) using finger pressure only (see Figure 12). Make sure seal is firmly and evenly seated.
4. Install rotating half of seal on impeller sleeve. Push it onto sleeve until it butts against back of impeller.
5. Insert impeller sleeve through center hole in seal plate (Key No. 9). Thread flinger (Key No. 7) over the end of the impeller sleeve.
6. If motor has been removed from motor cover, reinstall it now. Set up seal plate (Key No. 9) in front of motor cover; hold motor shaft with 7/16" wrench on shaft flats (under cap) and thread impeller through center hole in seal plate onto shaft. Make sure that flinger is in place on impeller sleeve – not loose on shaft.
7. Install motor throughbolts; make sure seal plate butts firmly against motor endbell.
8. Install front plate (Key No. 13). Tighten cap screws in sequence as shown in Figure 13; tighten to 30 inch-lbs. (34.5 cm-kg.) torque.
9. Reinstall drain plugs; reinstall pump and motor on base and tighten hold-down bolts.
10. Reconnect unions; tighten hand tight only.

## TROUBLESHOOTING GUIDE – PUMP

 **Read and understand safety and operating instructions in this manual before doing any work on pump.**

### **A. Pump does not operate:**

1. Check GFCI (Ground Fault Circuit Interrupter) for proper operation according to GFCI manufacturer's instructions.
2. Check for blown fuses, circuit breakers, or disconnected electrical wiring.
3. Check for sand locked impeller. Disconnect power to motor; follow pump disassembly instructions, Pages 10 and 11. Clean out sand from impeller and from wear ring in front plate. Reassemble according to instructions, Page 11.
4. Consult dealer/installer or service representative.

### **B. Motor runs, but does not pump water or pressurize system:**

1. Check to make sure all valves are open.
2. Check skimmer, trap basket, and piping for debris or obstructions.
3. Check pump impeller for obstructions such as hair, leaves, grass, or stones. Follow "Pump Disassembly" instructions, under "Pump Service" on Pages 10 and 11.
4. Consult with dealer/installer or service representative.

### **C. Excessive air in system – pump loses prime:**

1. Make sure water level in skimmer is at least 2" above bottom of skimmer throat with system not operating.
2. Make sure that there are no leaves in suction piping and skimmer basket.
3. Make sure there is no vortex (whirlpool) at the skimmer suction; add water to pool if necessary.
4. Consult dealer/installer or service representative.

### **D. Circuit breaker in home panel trips repeatedly:**

1. Breaker must be of correct rating (see Page 6).
2. If breaker is a GFCI breaker, test according to GFCI manufacturer's instructions.
3. Be sure no other lights and appliances are on circuit.
4. Check wiring size leading to pump. Undersize wire will cause overheating and excessive amp draw, leading to the circuit breaker tripping. Circuit wiring to the receptacle serving the pump must meet code for the load on the circuit. If in doubt, consult a licensed electrician.
5. Consult dealer/installer or service representative.

# TROUBLESHOOTING GUIDE – FILTER

## 1. Short Cycle Time:

**NOTICE:** Cycle Time will vary with each installation and between different areas of the country. The following causes and remedies are for cycle times shorter than normal for your area.

- A. Chlorine residual too low; maintain proper residual (consult pool professional for recommendation).
- B. Flow rate too high; restrict flow to rated capacity of filter (see instruction plate on filter or specifications on Page 4).
- C. Filter is too small; install an additional filter.
- D. Filter module is dirty or plugged; thoroughly clean the filter (see No. 4, "Plugged Module Cloth", and "Module Cleaning Procedure", Page 9).
- E. Water is chemically out of balance; consult pool professional.
- F. Algae in the pool. Apply heavy dose of chlorine or algicide as recommended by the pool manufacturer.

## 2. Low Flow/High Pressure:

- A. Elements plugged; clean filter thoroughly (see Page 9).
- B. Pipe blocked downstream from filter; remove obstruction.
- C. Piping too small; use larger pipe (consult dealer for sizing).
- D. Filter area too small; install an auxiliary filter (consult dealer for recommendation).
- E. Outlet port check valve obstructed (if applicable); remove obstruction to allow valve to open.

## 3. Low Flow/Low Pressure:

- A. Pump too small; consult dealer for recommendations.
- B. Plugged pump or plugged hair and lint trap; clean thoroughly.

## 4. Plugged Module Cloth:

- A. Insufficient cleaning; follow cleaning instructions closely and clean thoroughly (see Page 9).
- B. Water is chemically out of balance; consult pool professional.

C. Excessive air in filter. Vent air from tank and check for pump suction pipe leaks. Clean air bleed filter in module assembly with a hose and soft flow nozzle.

D. Filter is too small. Install an additional filter.

E. Pool water contains iron. See "Special Cleaning Instructions", Page 9.

F. Heavy or improper application of powdered chlorine tablets using a binder. See "Special Cleaning Instructions", Page 9.

G. Algae in the pool. Apply heavy dose of chlorine or algicide as recommended by the pool manufacturer.

H. Use of incorrect chemicals with PHMB sanitizers. Replace filter module.

## 5. Pool Water Not Clean:

A. Chlorine residual too low; maintain adequate chlorine residual (consult pool service technician for recommendation).

B. Filter module cloth torn, plugged, or punctured; replace module.

C. Inadequate turnover rate; consult dealer to verify that equipment is properly sized for your pool.

D. Pump is too large and is overpumping. Reduce the flow rate.

E. The filter is installed backwards. Reinstall it correctly.

F. Pool water contains iron. See "Special Cleaning Instructions", Page 9.

G. Heavy or improper application of powdered chlorine tablets using a binder. See "Special Cleaning Instructions", Page 9.

H. Algae in the pool. Apply heavy dose of chlorine or algicide as recommended by the pool manufacturer.

## 6. Pool Accessories Stop Working:

A. Clean filter and observe performance of accessories.

B. If accessories perform better after filter has been cleaned, use a shorter cleaning cycle for the filter (that is, clean the filter after a pressure rise of less than 10 PSI).

**REPAIR PARTS LIST**  
**Modular Media Filter Systems**  
 See Page 15 for Filter Tank Assembly Parts  
 See Pages 16 and 17 for Pump Parts

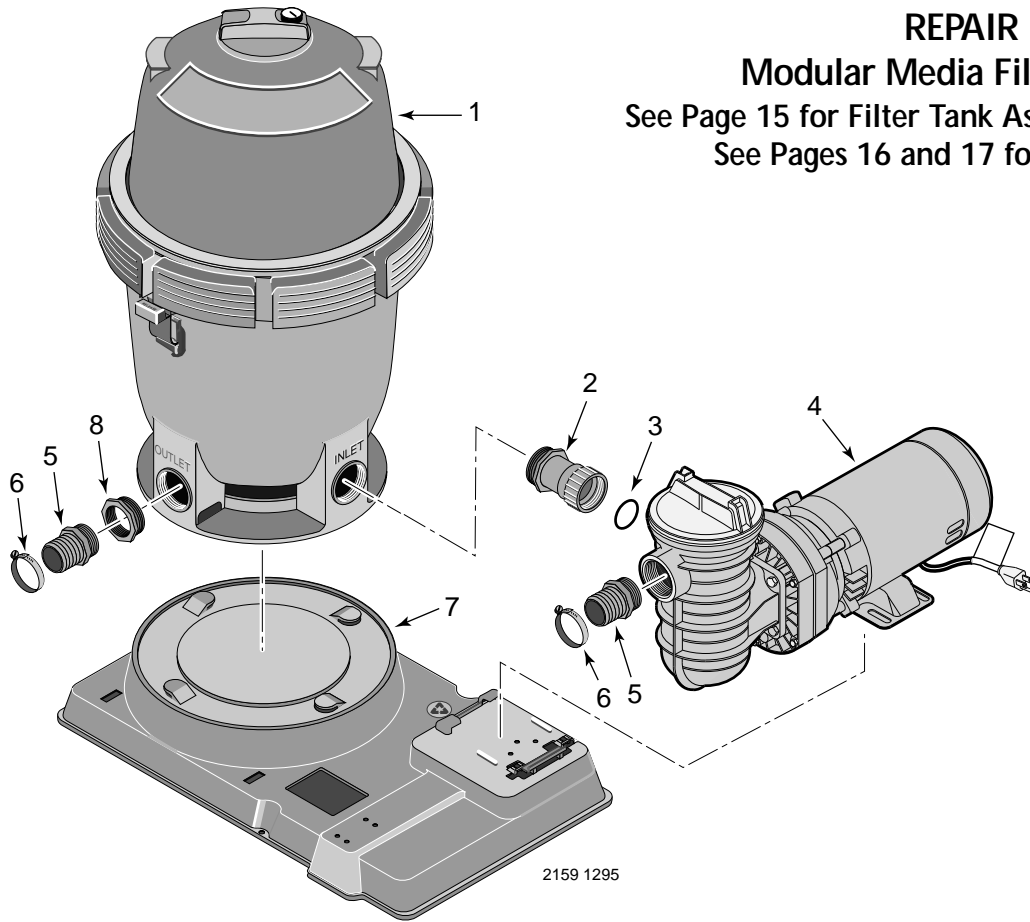

**REPAIR PARTS LIST – Modular Media System**

Key No.	Part Description	Qty.	Model No.			
			PLM100JWAE-03	PLM100JWAF-03	PLM150JWAE-03	PLM150JWAF-03
			1 HP	1-1/2 HP	1 HP	1-1/2 HP
1	Filter Tank Assembly	1	PLM100	PLM100	PLM150	PLM150
2	Union Half Assembly	1	27001-0120	27001-0120	27001-0120	27001-0120
3	O-Ring	1	U9-226	U9-226	U9-226	U9-226
4	Pump Assembly (-03, -04 Models)	1	JWPA5E7L-2A2	JWPA5F7L-2A2	JWPA5E7L-A2	JWPA5F7L-2A2
4	Pump Assembly (-06 Models)	1	JWPA5E7C-2A3U	JWPS5F7C-2A3U	JWPA5E7C-2A3U	JWPS5F7C-2A3U
4	Pump Assembly (-12 Models)	1	JWPA5E7L-2A1	JWPA5F7L-2A1	JWPA5E7L-2A1	JWPA5F7L-2A1
4	Pump Assembly (-15 Models)	1	–	JWPA5YF7L-A1	–	–
•	Adapter Kit (includes Key No. 6, 7)	1	27001-0141	27001-0141	27001-0141	27001-0141
5	Hose Adapter 1-1/2" MPT Male	2	11201-0002	11201-0002	11201-0002	11201-0002
6	Hose Clamp	4	P19-30	P19-30	P19-30	P19-30
7	Platform Base	1	27001-0031	27001-0031	27001-0031	27001-0031
8	2" NPT x 1-1/2" NPT Reducer Bushing	1	U78-820P	U78-820P	U78-820P	U78-820P
•	System Nameplate	1	27002-0045	27002-0045	27002-0045	27002-0045
•	Hose Assembly 1-1/2" X 77" (-03 Models only)	2	34055-7038	34055-7038	34055-7038	34055-7038
•	Platform Extension (Optional)	1	27001-0032	27001-0032	27001-0032	27001-0032

• Not illustrated.

# REPAIR PARTS

## Filter Tank Assembly

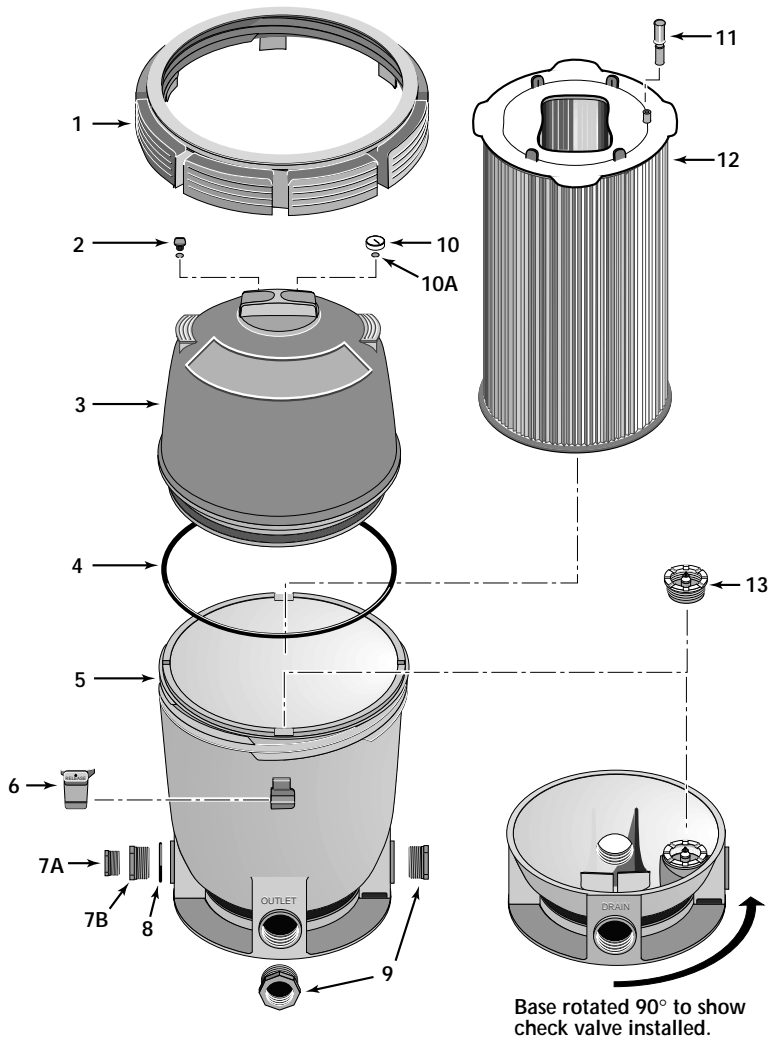

Key No.	Description	Qty.	Part Number
1	Posi-Lok™ ring*	1	27001-0050B
2	Air release valve assembly	1	25010-0200
3	Tank shell upper half*	1	27001-0020S
4	Tank O-ring	1	27001-0061S
5	Tank shell lower half	1	27001-0009S
6	Safety latch for ring	1	27001-0051
7A	1-1/2" NPT plug	1	11201-0005B
7B	Adapter fitting	1	24900-0509
8	O-ring	1	35505-1424
9	2" x 1-1/2" Pipe reducer***	2	U78-820P
10	Pressure gauge***	1	15060-0000T
10A	Pressure gauge screen***	1	WC8-72D
11	Air bleed assembly	1	24800-0121
12	Filter module (PLM100)	1	27002-0100S
12	Filter module (PLM150)	1	27002-0150S
13	Spring check valve**	1	27001-0130S
	• Accessory package	1	27001-0140
	• Decal, logo	1	27001-0041
	• Decal, warning	1	27001-0042
	• Decal, operating instr.	1	27002-0043
	• Decal, nameplate (PLM100)	1	27002-0042
	• Decal, nameplate (PLM150)	1	27002-0045
	• Owner's manual	1	S340
	• Teflon tape***	1	U97-58
	• O-ring grease***	1	34725-0013

- Not illustrated.
- \* Includes all decals and labels.
- \*\* Optional equipment.
- \*\*\* Shipped in accessory package.

## REPAIR PARTS LIST — 17290 SERIES PUMPS

See Pump nameplate for Pump Model Number  
for Filter System with Suffix -06

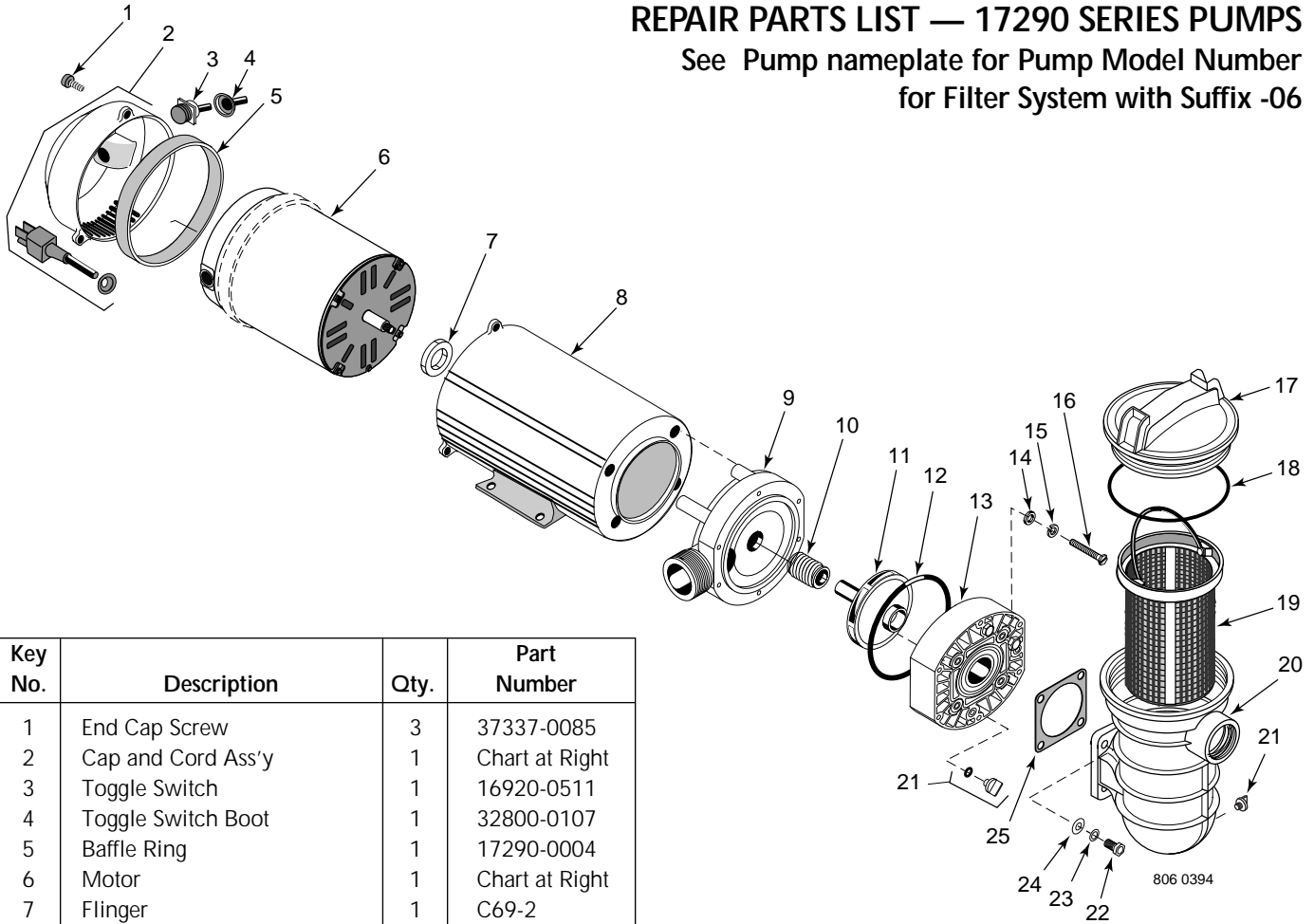

Key No.	Description	Qty.	Part Number
1	End Cap Screw	3	37337-0085
2	Cap and Cord Ass'y	1	Chart at Right
3	Toggle Switch	1	16920-0511
4	Toggle Switch Boot	1	32800-0107
5	Baffle Ring	1	17290-0004
6	Motor	1	Chart at Right
7	Flinger	1	C69-2
8	Motor Cover	1	17190-0021
9	Seal Plate	1	17301-0150
10	Shaft Seal	1	U9-358SS
11	Impeller	1	Chart at Right
12	O-Ring	1	U9-357
13	Front Plate	1	C101-272P
14	Plain Washer	4	U43-60SS
15	Lock Washer	4	U43-10SS
16	Cap Screw	4	U30-873SS
17	Trap Lid	1	C3-139P1
18	Trap Lid O-Ring	1	U9-229
19	Trap Basket	1	C108-33P
20	Trap Body	1	C153-53P
21	Drain Plug w/O-Ring	2	U178-920P
22	Cap Screw	4	U30-64SS
23	Lock Washer	4	U43-11SS
24	Plain Washer	4	U43-41SS
25	Trap Outlet Gasket	1	C20-123
26	Mounting Foot	1	17190-0023
	• Nameplate	1	32155-4073
	• Decal – GFCI Required	1	U27-558
	• Tag – Do Not Use Pipe Dope	1	61002-0002
	• Tag – Electrical, priming	1	61002-0004

Parts are common to all models listed except as noted;  
Key Nos. 6, Motor; and 11, Impeller, are listed below.

Model No. HP		Motor No. (Key No. 6)	Impeller No. (Key No. 11)
<b>115V/60/1</b>			
JWPA5E7C-2A3	1	AS901EL	C105-228PWS
JWPS5F7C-2A3	1-1/2SPL	AS901SFL	C105-228PWS
Model No.	HP	Cord & Cap Assembly	
<b>115V/60/1</b>			
JWPA5E7C-2A3	1	17190-0026-S	
JWPS5F7C-2A3	1-1/2SPL	17190-0026-S	

### Trap Cover/O-Ring Kit (5" Trap)

Kit includes C3-139P1 Trap Cover and U9-229 O-Ring.  
Parts-Pak No. PP2075.

## REPAIR PARTS LIST — JWA Series PUMPS

See Pump nameplate for Pump Model Number for Filter System with Suffix -03, -04, -12, or -15

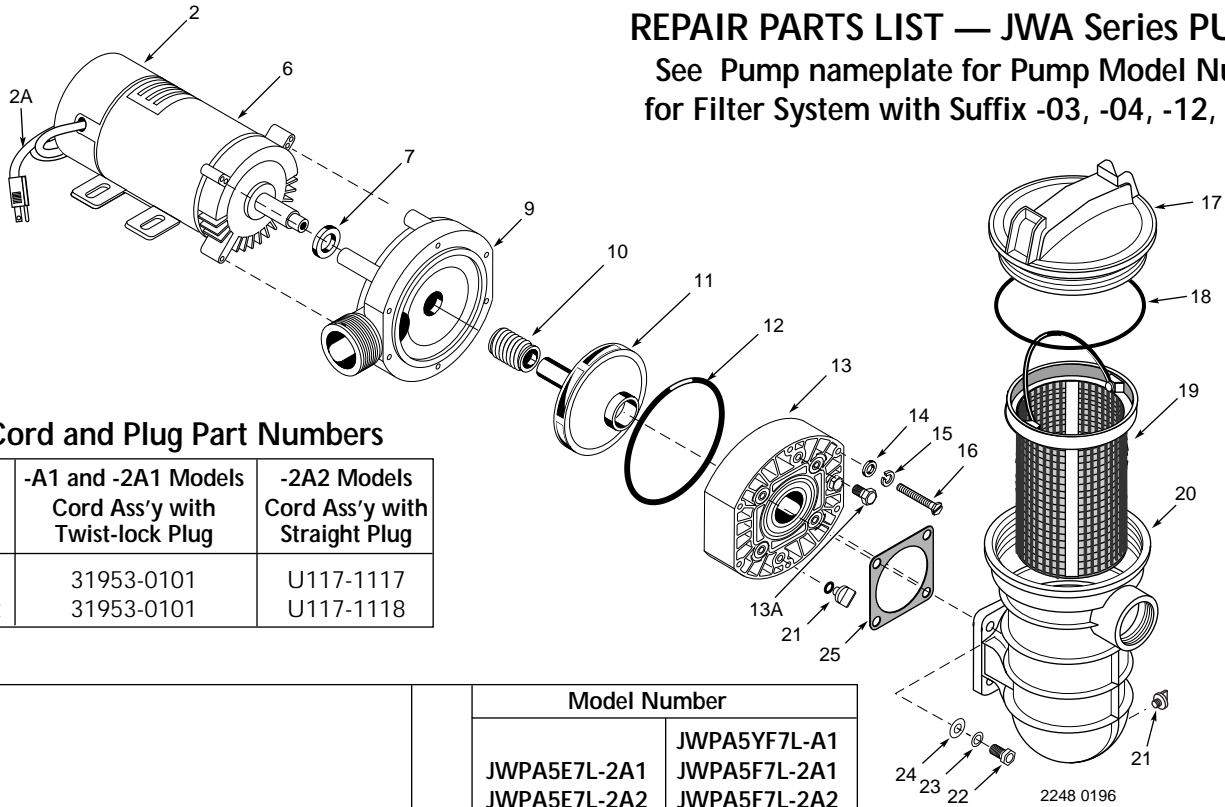

### Cord and Plug Part Numbers

HP	-A1 and -2A1 Models Cord Ass'y with Twist-lock Plug	-2A2 Models Cord Ass'y with Straight Plug
1	31953-0101	U117-1117
1-1/2	31953-0101	U117-1118

Key No.	Description	Qty.	Model Number	
			JWPA5E7L-2A1 JWPA5E7L-2A2 1 HP	JWPA5YF7L-A1 JWPA5F7L-2A1 JWPA5F7L-2A2 1-1/2 HP
2	Motor End Cap	1	Not Available separately	
2A	Cord Assembly	1	See Chart	See Chart
6	Motor 115/60H/1Ph (Without Cord)*	1	AS920ELL	AS920FLL
7	Slinger	1	C69-23	C69-23
9	Seal Plate	1	C1-260P	C1-260P
10	Seal	1	U109-358SS	U109-358SS
11	Impeller	1	C105-228PG	17301-0101
12	O-Ring	1	U9-357	U9-357
13	Front Plate	1	C101-272P	C101-272P
13A	Pipe Plug	2	WC78-40T	WC78-40T
14	Washer, 1/4 Flat	6	U43-117SS	U43-117SS
15	Washer, 1/4 Lock	6	U43-10SS	U43-10SS
16	Screw, 1/4-20x1-3/4	6	U30-873SS	U30-873SS
17	Trap Cover	1	C3-139P1	C3-139P1
18	O-Ring - Cover	1	U9-229	U9-229
19	Strainer Basket	1	C108-33P	C108-33P
20	Trap Body	1	C153-53P1	C153-53P1
21	Drain Plug - 1/4" NPT (w/O-Ring)	2	U178-920P	U178-920P
22	Capscrew 5/16-18x1-1/4"	4	U30-64SS	U30-64SS
23	Washer, Lock 5/16"	4	U43-11SS	U43-11SS
24	Washer, Flat 5/16"	4	U43-41SS	U43-41SS
25	Gasket	1	C20-123	C20-123
	• Nameplate	1	U33-155	U33-155
	• Decal "Tested for Pools & Spas"	1	U27-635	U27-635
	• Decal - GFCI required	1	U27-558	U27-558
	• Decal - Caution	1	32165-4038	32165-4038
	• Tag - bonding instructions	1	C63-12	C63-12
	• Tag - CAUTION Securely Tighten...Warning...	1	61002-0002	61002-0002

### Trap Cover/O-Ring Kit (5" Trap)

Kit includes C3-139P1 Trap Cover and U9-229 O-Ring.

Parts-Pak No. PP2075.

• Not illustrated.

\* Model JWPA5YF7L-A1 uses Part No. 62003-2032.



# LIMITED WARRANTY

Pentair Water Pool and Spa manufactures its products with the highest standards of workmanship, using the best materials available through state of the art processes. Pentair Water Pool and Spa warrants its products as follows:

**Limited Warranty:** Pentair Water Pool and Spa warrants its products to be free from defects in material and/or workmanship for a period of one (1) year (parts only) from the original date of purchase or installation.

**Exceptions that could result in denial of a warranty claim:**

1. Damage caused by careless handling, improper repackaging, or shipping.
2. Damage due to misapplication, misuse, abuse or failure to operate equipment as specified in the owners manual.
3. Damage caused by failure to install products as specified in the owners manual.
4. Damage due to unauthorized product modifications or failure to use Pentair Water Pool and Spa original replacement parts.
5. Damage caused by negligence, or failure to properly maintain products as specified in the owners manual.
6. Damage caused by failure to maintain water chemistry in conformity with the standards of the swimming pool industry for any length of time.
7. Damage caused by water freezing inside the product.
8. Accidental damage, fire, acts of God, or other circumstances outside the control of Pentair Water Pool and Spa.

**Specific Product Warranties (from date of installation):**

Product Family	Limited Warranty	Exceptions
Filters	1 year	
Aboveground Systems	1 year	
Pumps	1 year	
Heaters	2 years	MiniMax 75/100 - 1 year
Heat Pumps	2 years Parts and Labor	Compressor Parts and Labor - 10 years Titanium Heat Exchanger - Lifetime
Lights	1 year	Bulbs - 90 days
Automation Equipment	1 year	SunTouch Solar - 3 years
Automatic Pool Cleaners	1 year	
Robotic Pool Cleaners	1 year 200 Cleaner Cycles	
Kreepy Krauly Cleaners	2 years	Suction Seal, Foot Pad, Wings Bumper Strap - 1 year
Kreepy Kruiser, Great White Cleaners	2 years	
PoolShark Cleaners	2 years	Foot Pad, Seal Flaps - 1 year
Maintenance Equipment/ Replacement Parts	90 days	
White Goods	1 year	
Chlorine Bromine Feeders	1 year	

- This warranty extends to the original retail owner only, beginning on the date of installation and is not enforceable by any other party. Proof of purchase and/or date of installation will be required to execute a warranty claim. Original owner agrees to prepay all shipping charges to Pentair Water Pool and Spa.
- **Warranties by others:** Some products incorporate components manufactured by other manufacturers. Some of these provide warranties in addition to the warranty provided herein. In all such cases a copy of that warranty will be provided with the product. To the extent protection provided under any such third party warranty exceeds the Limited Warranty provided herein, the Customer will have to look to that manufacturer for the additional protection. (Continued On Other Side)



*Please Detach Along Dotted Line and Mail This Section. Keep the Warranty for Your Records.*  
**PRODUCT WARRANTY REGISTRATION CARD**

Please promptly complete and return this postage paid card. In the unlikely event we must notify you of safety modifications to your product, under the Consumer Product Safety Act, this will allow us to communicate with you quickly. Incomplete or missing information such as your serial number will not be registered. **Your Limited Warranty is attached to this reply card.** Please detach it, review it thoroughly so you are familiar with the terms of your warranty coverage and keep in a safe place.

**Product:**

- FILTER  PUMP  HEATER  HEAT PUMP  LIGHT  CONTROLS  
 AUTO CLEANER  AUTO FEEDER  MAINT. EQUIPMENT  WHITE GOODS

**Brand/Model Name:** \_\_\_\_\_

**I purchased the Pentair product for use in:** \_\_\_\_\_  
 Inground Pool  Inground Pool/Spa Combination  Aboveground Pool  Spa Only

**My Serial Number is:** \_\_\_\_\_  
*(if applicable)*

**1. Name:** \_\_\_\_\_  
*(Please Print)*

**Street Address:** \_\_\_\_\_

**City:** \_\_\_\_\_ **State:** \_\_\_\_\_ **Zip:** \_\_\_\_\_

**Tel. No.:** (\_\_\_\_) \_\_\_\_\_ **E-mail:** \_\_\_\_\_

**2. Date of Purchase/Installation:** \_\_\_\_\_  New  Replacement  
**Signature:** \_\_\_\_\_ **Date:** \_\_\_\_\_

**3. Where did you purchase your Pentair Product?**

- Pool Builder  Pool Store  Pool Service  Mail Order  Internet  Other

**Company Name:** \_\_\_\_\_

**Location:** \_\_\_\_\_

**4. Please indicate how your pool and/or spa is presently equipped.** (Check all that apply.)

- Heater (Approx. age \_\_\_\_\_)  Heat Pump (Approx. age \_\_\_\_\_)  Automatic Pool Cleaner  
 Automatic Control System  Fiber-Optic Perimeter or Landscape Lights  Automatic Chlorine Generator  
 Underwater Color Changing Lights  Chlorine Bromine In-Line (Plumbed) Feeder

**5. Please indicate how important each of the following factors were in your buying decision:**

	Very Important	Important	Somewhat Important	Not Important
Previous use of product	<input type="checkbox"/>	<input type="checkbox"/>	<input type="checkbox"/>	<input type="checkbox"/>
Sale price	<input type="checkbox"/>	<input type="checkbox"/>	<input type="checkbox"/>	<input type="checkbox"/>
Recommendation of others	<input type="checkbox"/>	<input type="checkbox"/>	<input type="checkbox"/>	<input type="checkbox"/>
Recommendation of salesperson	<input type="checkbox"/>	<input type="checkbox"/>	<input type="checkbox"/>	<input type="checkbox"/>
Reputation of store or builder	<input type="checkbox"/>	<input type="checkbox"/>	<input type="checkbox"/>	<input type="checkbox"/>
Reputation for customer service	<input type="checkbox"/>	<input type="checkbox"/>	<input type="checkbox"/>	<input type="checkbox"/>
Reputation for quality/durability	<input type="checkbox"/>	<input type="checkbox"/>	<input type="checkbox"/>	<input type="checkbox"/>
Style/appearance	<input type="checkbox"/>	<input type="checkbox"/>	<input type="checkbox"/>	<input type="checkbox"/>
Value for the price	<input type="checkbox"/>	<input type="checkbox"/>	<input type="checkbox"/>	<input type="checkbox"/>
Warranty	<input type="checkbox"/>	<input type="checkbox"/>	<input type="checkbox"/>	<input type="checkbox"/>

**6. This product replaces a:** \_\_\_\_\_  
(Brand)

**Warranty Note:** Automatic Cleaners purchased in the USA from entities outside the USA do not qualify for any USA programs including warranty, trade-in or rebate programs.

*Thanks for taking the time to fill out this questionnaire. Your answers will help us to better serve you in the future.*



FOLD IN HALF AND SEAL FOR MAILING



PENTAIR WATER POOL AND SPA  
PO BOX 101480  
FT LAUDERDALE FL 33310-9947

POSTAGE WILL BE PAID BY ADDRESSEE

BUSINESS REPLY MAIL  
FIRST-CLASS MAIL PERMIT 29 FT LAUDERDALE FL

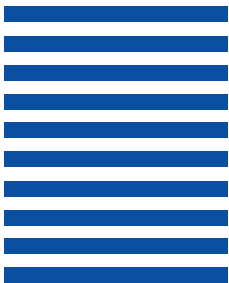

NO POSTAGE  
NECESSARY  
IF MAILED  
IN THE  
UNITED STATES



# LIMITED WARRANTY

(Continued From Other Side)

### Warranty Obligations of Pentair Water Pool and Spa

Should a defect in workmanship and/or material in any item covered by this warranty become evident during the term of the warranty, then upon the consumer following the procedures set forth below, Pentair Water will, at its option, repair or replace such item or part at its own cost and expense.

Pentair Water is not, however, responsible under this warranty for any cost of shipping or transportation of the equipment or parts thereof to or from the Technical Service Department. Also, Pentair Water is not liable for any loss of time, inconvenience, incidental expenses such as telephone calls, labor or material charges incurred in connection with the removal or replacement of the equipment, or any other incidental or consequential damages.

This warranty is void if the product is repaired or altered in any way by any persons, agents or representatives other than those authorized by Pentair. Expendables including, but not limited to refrigerant, recovery of refrigerant, or transportation for components are not covered under this limited warranty. Reasonable vehicle trip and evaluation charges may be assessed by the service representative. Pentair, at its sole discretion, reserves the right to provide a replacement product or part, of equal value, in lieu of repair.

**PLEASE NOTE:** Some states do not allow the exclusion or limitation of incidental or consequential damages, so the above limitation or exclusion may not apply to you.

### No Other Warranties

To the maximum extent permitted by applicable law, Pentair Water disclaims all other warranties, either expressed or implied, including, but not limited to, implied warranties of merchantability and fitness for a particular purpose, with regard to the Product(s), Part(s) and/or any accompanying written materials.

### Procedure for Obtaining Performance

In order to obtain the benefits of this warranty, the consumer who made the original retail purchase must contact the Pentair Water Technical Service Department as soon as possible after discovery of the defect, but in no event later than the expiration date of the warranty period provided in this warranty. Upon receipt of this communication, Pentair Water will promptly notify the customer of the address to which the defective item may be shipped. The customer shall then ship the item, freight prepaid, to the address indicated, together with a "RETURN GOODS AUTHORIZATION" form obtained from Technical Service and a brief description of the problems encountered. Unauthorized returns will not be accepted. Freight must be prepaid by customer.

### Warranties or Representations by Others

No dealer or other person has any authority to make any warranties or representation concerning Pentair Water or its products. Accordingly, Pentair Water Pool and Spa is not responsible for any such warranties or representations.

### Other Rights

This warranty gives you specific legal rights and you may also have other rights, which vary from state to state.

### Sole Warranty

Supersedes all previous publications.

### PENTAIR WATER POOL AND SPA, INC.

1620 Hawkins Ave. Sanford, NC 27330  
10951 W. Los Angeles Ave. Moorpark, CA 93021  
Phone: 800-831-7133 Fax: 800-284-4151