

STA-RITE®

CRISTAL-FLO™ HIGH RATE SAND FILTERS

O W N E R ' S M A N U A L

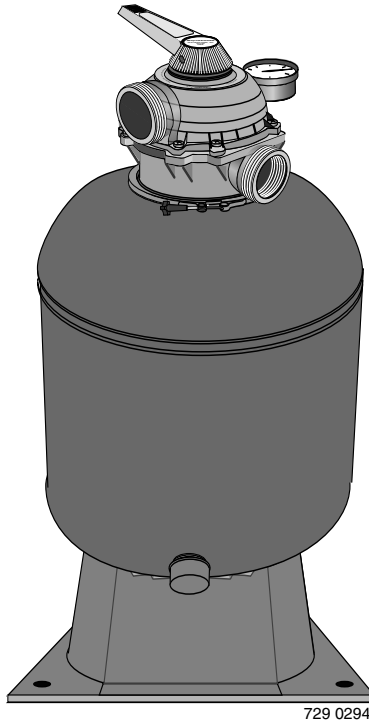

729 0294

INSTALLATION, OPERATION & PARTS

MODELS

T-150BP-1 T-170BP-1 T-200BP-1 T-240BP-1 T-300BP-2



This manual should be furnished to the end user of this filter; its use will reduce service calls and chance of injury and will lengthen filter life.

Sta-Rite Pool/Spa Group

Pentair Pool Products, Inc.

1620 Hawkins Ave.
Sanford, NC 27330
Tel 919-774-4151 • Fax 919-774-4841



Because reliability matters most

© 2005, Sta-Rite Industries

S242 (Rev. B 6/28/06)

HIGH RATE SAND FILTERS

To avoid unneeded service calls, prevent possible injuries, and get the most out of your filter, READ THIS MANUAL CAREFULLY!

The Sta-Rite Top Mounted Series High Rate Sand Filter:

- Is designed to filter water for swimming pools.
- Is an excellent performer; durable, reliable.

Table of Contents

Safety Instructions	2-3
Dimensions/Specifications	4
General Information	5
Installation	5-7
Filter Mount/Piping	5
Filter Set-up	6
Loading Sand Media	6
Valve Installation	6
Startup/Operation	7
Maintenance	8
Water Maintenance	8
Storage/Winterizing	8-10
Mult-Port Valve Service	9
Drain Fitting Installation/Removal	10
Troubleshooting Guide.....	11
Repair Parts List.....	12-13
Pressure Drop Curve.....	14
Warranty	15

READ AND FOLLOW SAFETY INSTRUCTIONS!

 This is the safety-alert symbol. When you see this symbol on your valve or in this manual, look for one of the following signal words and be alert to the potential for personal injury.

 **DANGER** warns about hazards that **will** cause serious personal injury, death or major property damage if ignored.

 **WARNING** warns about hazards that **can** cause serious personal injury, death or major property damage if ignored.

 **CAUTION** warns about hazards that **will** or **can** cause minor personal injury or property damage if ignored.

The label **NOTICE** indicates special instructions which are important but not related to hazards.

Carefully read and follow all safety instructions in this manual and on filter.

Keep safety labels in good condition.
Replace missing or damaged safety labels.



Incorrectly installed or tested equipment may fail, causing severe injury or property damage. Read and follow instructions in owner's manual when installing and operating equipment. Have a trained pool professional perform all pressure tests.

1. Do not connect system to a high pressure or city water system.
2. Use equipment only in a swimming pool installation.
3. Trapped air in system can cause explosion. BE SURE all air is out of system before operating or testing equipment.

Before pressure testing, make the following safety checks:

- Check all clamps, bolts, lids, and system accessories before testing.
- BE SURE all air is out of system before testing.
- Tighten Sta-Rite trap lids to 30 ft. lbs. (4.1 kg-cm) torque for testing.
- Water pressure for test must be less than 25 PSI (172 kPa).
- Water temperature for test must be less than 95° F. (35° C).
- Limit test to 24 hours. After test, visually check system to be sure it is ready for operation. Remove trap lid and retighten hand tight only.

NOTICE: These parameters apply to Sta-Rite equipment only. For non-Sta-Rite equipment, consult manufacturer.

	<p>⚠ DANGER</p>	<p>BEFORE WORKING ON FILTER:</p>
	<p>Hazardous Pressure! Can cause severe injury or major property damage from tank explosion.</p>	<ol style="list-style-type: none"> 1. Stop pump. 2. Open air release valve. 3. Release all pressure from system.
	<p>⚠ WARNING</p>	<p>BEFORE WORKING ON PUMP OR MOTOR</p>
	<p>Filter pumps require hazardous voltage which can shock, burn, or cause death.</p>	<p>Disconnect power to motor.</p>

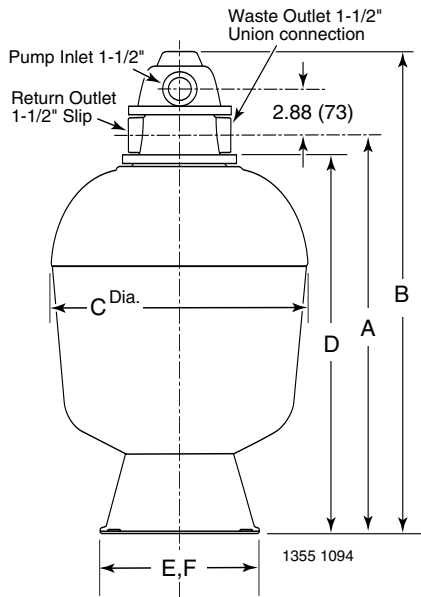

Fig. 1: Dimensions, T-150BP-1, T-170BP-1 T-200BP-1, T240BP-1

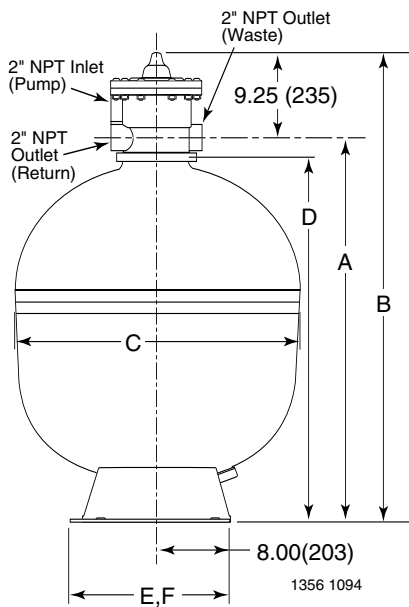

Fig. 2: Dimensions, T-300BP-2, T240BP-2

See Page 14 for Pressure Drop Curve.

RECOMMENDED SAND GRADES:

Use only: #20 Silica Sand, Size Range .40-.55mm., Uniformity Coefficient less than 1.75.

NOTICE: Use of other sands will reduce filter performance, may damage pump, and will void warranty.

Recommended:

1. Wedron Silica/Best Sand Co., Sand Grade: Wedron .45-.55mm., Effective Size .46mm, Uniformity Coefficient 1.22.
2. U.S. Silica - Silurian Filter Sand, Sand Grade.45-.55 mm., Effective Size .48mm, Uniformity Coefficient 1.18.

TABLE I - FILTER OPERATIONAL DATA

Filter Model	Filter Size		Max. Flow Rate in GPM (L/M)
	Dia. in Inches (mm)	Area in Ft ² (M ²)	
T-150BP-1	15 (381)	1.26 (.117)	25.2 (95)
T-170BP-1	17 (432)	1.57 (.146)	31.5 (123)
T-200BP-1	20 (508)	2.18 (.203)	43.6 (165)
T-240BP-1	24 (610)	3.10 (.288)	62.0 (234.7)
T-240BP-2	24 (610)	3.10 (.288)	62.0 (234.7)
T-300BP-2	30 (762)	4.90 (.455)	98 (371)

Filter Model	Turnover in Hours				Sand Volume in lbs. (kg.)
	6	8	10	12	
	gal. (L)	gal. (L)	gal. (L)	gal. (L)	
T-150BP-1	9,070(34 330)	12,100(45 799)	15,120(57 229)	18,144(68 675)	100 (45.4)
T-170BP-1	11,340(42 922)	15,120(57 229)	18,900(71 536)	22,680(85 844)	150 (68)
T-200BP-1	15,700(59 424)	20,930(79 220)	26,160(99 016)	31,390(118 811)	200 (90.7)
T-240BP-1	22,230(84 481)	29,760(112 642)	37,200(140 802)	44,640(168 962)	300 (136)
T-240BP-2	22,230(84 481)	29,760(112 642)	37,200(140 802)	44,640(168 962)	300 (136)
T-300BP-2	35,280(133 535)	47,040(178 046)	58,800(222 558)	70,560(267 070)	600 (272)

*NOTE: 1 cubic foot of sand weighs approx. 100 lbs. (45.4 kg). Do not use finer or coarser grade than recommended for best performance.

TABLE II - DIMENSIONAL DATA In Inches (mm)

Filter Model No.	A	B	C	D	Base Width (E)	Base Length (F)	Piping Port Size
T-150BP-1	27 (686)	33-13/16 (859)	15-3/4 (400)	24-11/16 (627)	13 (330)	16-1/4 (413)	1-1/2" SLIP
T-170BP-1	29-9/16 (751)	36-3/8 (924)	17-3/4 (451)	27-1/4 (692)	13 (330)	16-1/4 (413)	1-1/2" SLIP
T-200BP-1	31-5/8 (803)	38-1/2 (978)	20-3/4 (527)	29-3/8 (746)	13 (330)	16-1/4 (413)	1-1/2" SLIP
T-240BP-1	35-3/16 (897)	42 (1067)	24-3/4 (629)	32-7/8 (835)	16-7/8 (429)	21 (533)	1-1/2" SLIP
T-240BP-2	35-1/4 (895)	44-1/2 (1130)	24-3/4 (629)	32-7/8 (835)	16-7/8 (429)	21 (533)	2" (NPT)
T-300BP-2	42 (1067)	51-1/4 (1302)	31 (787)	39-5/8 (1008)	16-7/8 (429)	21 (533)	2" (NPT)

GENERAL INFORMATION

- Clean a new pool as well as possible before filling pool and operating filter. Excess dirt and large particles of foreign matter in the system can cause serious damage to the filter and pump.

⚠ NEVER test this filter with compressed air.

⚠ Do not operate filter at water temperatures above 95°F (35°C).

⚠ NEVER operate this filter system at more than 50 pounds per square inch (50 PSI/345 kPa) pressure!

INSTALLATION

Installation of filter should only be done by qualified, licensed personnel.

For assembly and filling instructions, see page 6.

Filter mount must:

- Provide weather and freezing protection.
- Provide space and lighting for easy access for routine maintenance. (See Figures 1 and 2, Table II, Page 4, for space requirements.)
- Be on a reasonably level surface and provide adequate drainage.
- Be as close to pool as possible to reduce line loss from pipe friction.

Piping:

- Piping must conform to local/state plumbing and sanitary codes.
- Use pipe joint sealing compound or teflon tape on all male connections of metal pipe and fittings (except unions). Use teflon tape or Plasto-Joint Stik¹ on all male connections of plastic pipe and fittings. **DO NOT use pipe dope on plastic pipe; it will cause the pipe to crack. Do not use sealant or tape on unions – assemble them dry and hand tight.**
- Do not damage union sealing surfaces and “O” Rings.
- Support pipe independently to prevent strains on filter or valve.
- Use 1-1/2 or 2” pipe to reduce pressure losses as much as possible.
NOTICE: Filter may be located away from pool, but for adequate flow larger pipe may be needed. Check local codes when considering remote installation.
- Fittings restrict flow; for best efficiency use fewest possible fittings.
- Keep piping tight and free of leaks: pump suction line leaks may cause trapped air in filter tank or loss of prime at pump; pump discharge line leaks may show up as dampness or jets of water.
- When unions are provided, use as follows for leak free connections:
 1. O-Ring and sealing surfaces must be clean.
 2. Assemble hand tight only (**no wrenches**).
 3. No pipe compound or teflon tape on unions.

Valves:

- A check valve installed between filter and heater will prevent hot water from backing up into filter and deforming internal components.
- Use care before assembly not to damage union sealing surfaces or O Ring.

Wastewater:

- Be sure all provisions for waste water disposal meet applicable local, state or national codes. 100 gallons (379 liters) or more of pool water will be discharged during filter backwashing. Do not discharge where water will cause flooding or damage.

¹ Lake Chemical Co., Chicago, IL

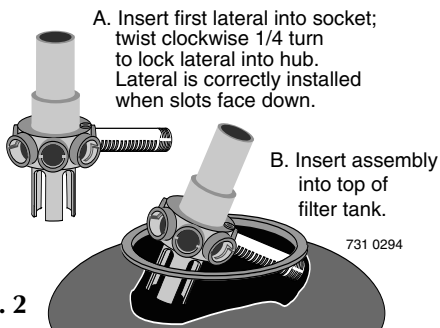

Fig. 2

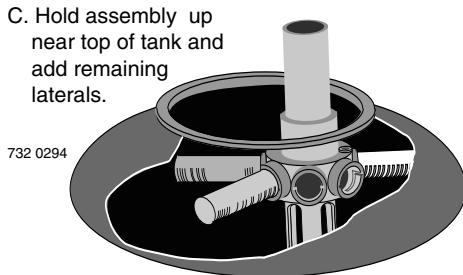

Fig. 3

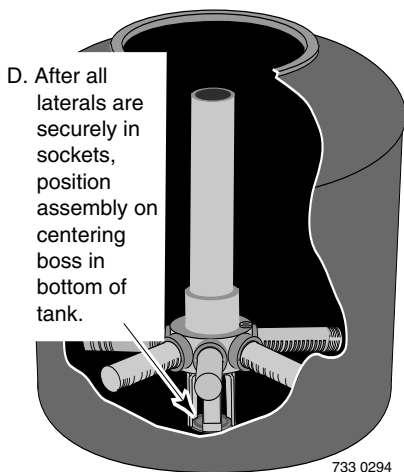

Fig. 4

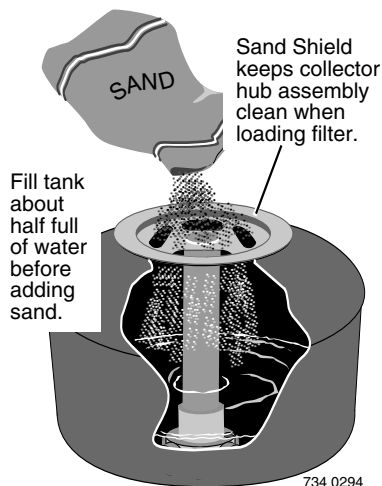

Fig. 5

Filter Setup

Assembly: See Figures 2 through 5 for filter assembly.

Loading Sand Media

1. To keep sand out of collector assembly, place plastic sand shield over top of collector tube before pouring sand into filter (See Figure 5).
2. To support laterals and prevent lateral breakage during loading, fill tank about half full of water before loading sand.
3. Pour sand into filter tank. See Page 4, for correct type and quantity of sand to use.

NOTICE: Make sure gasket area on top of tank is free of sand before installing valve and clamp.

4. Before installing valve, double-check that correct quantity of sand has been loaded (see Page 4).
5. Remove plastic sand loading shield and keep for future use.

Valve Installation:

See Figures 6, 7, and 8

1. Install O-Ring on valve flange; make sure O-Ring is clean, dry, and has no nicks, tears, or scrapes.
2. Make sure tank and valve flanges are clean and free of sand; put valve on top of tank. Vertical pipe of collector assembly inserts into base of valve.
3. Install clamp; make sure knob is positioned for easy access for filter maintenance. Valve port labeled "PUMP" should point toward pump.
4. Tighten clamp knob until clamp ends (under bolt) are 1/4" (6mm) apart. Tap around outside of clamp with a mallet to help seat clamp.

▲ WARNING Hazardous pressure. Clamp will not hold unless it is seated properly! DO NOT START PUMP until clamp ends are 1/4" (6mm) apart or less.

5. If clamp will not pull up to 1/4" (6mm) gap, wait 15-30 minutes and retighten. Tap clamp gently with mallet to help seat clamp.
6. Connect pipe from pump discharge to valve port labeled "PUMP"; use union half provided. Assemble union as follows for leakfree operation:
 - A. O-Ring and sealing surfaces must be clean.
 - B. Assemble hand tight only (no wrenches).
 - C. NO pipe compound or teflon tape on unions.
7. Complete all plumbing connections (see Page 5 for piping requirements).
 - A. Pipe from valve RETURN port to pool return.
 - B. Pipe from valve WASTE port to waste.
 - C. Suction piping from pool to trap inlet on pump.
8. System is ready for startup.

NOTICE: If there are leaks from beneath valve/clamp area, STOP PUMP, release all pressure, remove clamp and valve and clean sealing surfaces.

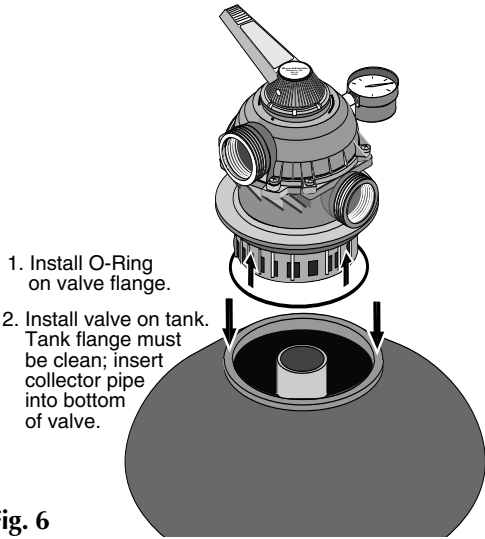

Fig. 6

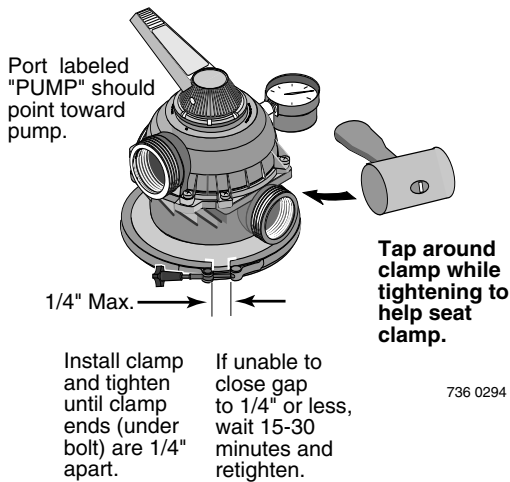

Fig. 7

Startup/Operation (See Figure 9)

⚠ WARNING Hazardous pressure. To avoid explosion and possible severe or fatal injury, filter system pressure must not exceed 50 PSI (345 kPa) under any circumstances. NEVER test this filter system with compressed air; never operate system with water temperature above 95° F (35° C).

⚠ CAUTION To prevent equipment damage and possible injury, turn pump OFF before changing valve position.

NOTICE: Do not add chemicals directly into the pool skimmer. Adding undiluted chemicals may damage equipment and void warranty.

1. Open system valves and make sure pump is filled with water. Make sure pool water level is 2" (51 mm) above bottom of skimmer opening.

2. With pump OFF, set valve to 'BACKWASH' position.

3. Start pump, circulating water backwards through filter to waste. Do not install pressure gauge until a steady stream of water runs out of gauge port; then stop pump and install gauge.

NOTICE: To prevent pump from running dry, be sure water level never drops below bottom of skimmer inlet. Add water to pool if necessary to keep skimmer flooded while backwashing and rinsing.

4. Backwash until water runs clear (3-5 minutes).

5. Stop pump; set valve to 'RINSE' position.

6. Start pump; run pump for one minute.

7. Stop pump; set valve to 'FILTER' position.

8. Filter is now ready for service.

9. Record clean starting filter pressure gauge reading as a reference.

10. When pool is first filled, backwash once a day until pool water is sparkling clear. After that, backwash when pressure gauge shows 5 to 7 PSI (34.5 to 48 kPa) higher than starting pressure.

Valve Setting	Purpose/Flow	Valve Setting	Purpose/Flow	Valve Setting	Purpose/Flow
	FILTER Normal filtration and vacuuming; water goes through filter to pool.		BACKWASH Reverses flow for cleaning; water goes through filter to waste.		WASTE Lowers pool level or drains pool; water bypasses filter, goes to waste.
	RINSE For initial startup cleaning and sand bed leveling after backwash; water goes through filter to waste.		CLOSED Shuts off all flow to filter and pool.	743 029	
	RECIRCULATE Circulates pool water; bypasses filter.		WINTERIZE Leaves all valve ports partially open for winter storage.	737 029	

Fig. 8

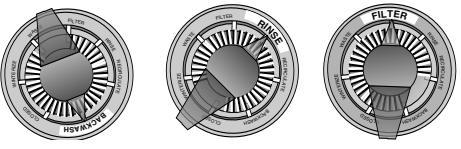

Fig. 9: Valve settings for startup. Stop pump before changing valve position.

MAINTENANCE

General:

- Wash outside of filter with a mild detergent and water. Rinse off with hose.
NOTICE: DO NOT use solvents to clean filter; solvents may damage plastic components in system.
- Inspect sand bed at least once a year to remove foreign material which has not been backwashed out of system.
NOTICE: When the sand bed gets hard and crusty on top, remove all the old sand and replace it with new sand.

Weekly Pool Equipment Inspection:

1. Check pressure during operation. When pressure is 5 to 7 PSI (34.5 to 48 kPa) higher than initial operating pressure, backwash filter (see instructions under "Startup/Operation", Page 7).
2. Except during hot weather with heavy swimmer loads, operating filter 6 to 12 hours per day should be sufficient. Carefully monitor water chemical balance and follow recommendations of your local pool professional.

Water Maintenance

- Keep water level at least 2" (51mm) above bottom of skimmer opening. Failure to do so can allow air to enter system, causing pump to lose prime and air to enter filter.
- Maintain pH at 7.2 to 7.6 in pool.



To prevent damage to system components, keep water temperature below 95° F. (35° C) at all times.

Vacuum Pool:

1. Fill vacuum hose by submerging in water from one end to the other.
2. To vacuum, insert hose into skimmer suction manifold or into vacuum line in pool wall. See instructions provided by pool builder or pool manufacturer. Start pump, making sure it is primed and pumping.
3. After vacuuming, clean pump trap to remove accumulated debris, then check filter pressure gage. If reading is 5 to 7 PSI (34.5 to 48 kPa) higher than initial operating pressure, backwash filter.

Lower or Drain Pool

1. Turn pump 'OFF'; set valve handle to 'WASTE'.
2. Use vacuum cleaner hose and head.
3. Start pump; run until pool is lowered to desired level.
4. Turn pump 'OFF'; set valve handle to 'FILTER'.
5. Start pump.

STORAGE/WINTERIZING

CAUTION Pool chemicals may give off corrosive fumes. Store chemicals away from system in a well ventilated area.

NOTICE: Allowing water to freeze will damage filter and void warranty. If antifreeze is needed, use propylene glycol; it's plastic compatible and non-toxic. Follow manufacturers instructions. Do not use ethylene glycol based anti-freeze – it's toxic and it may damage plastic components.

1. Open all system valves. Set multiport valve at 'WINTERIZE' to allow air passage to all ports.

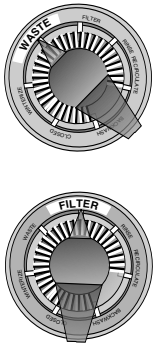

Fig. 10: Valve settings to lower pool water level. Stop pump before changing valve position.

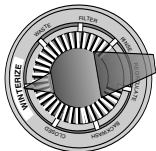
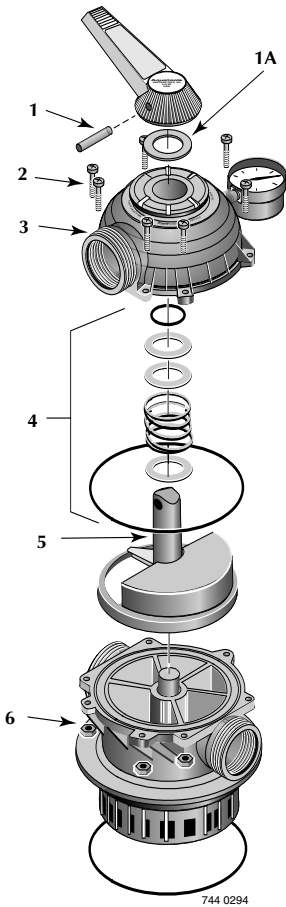
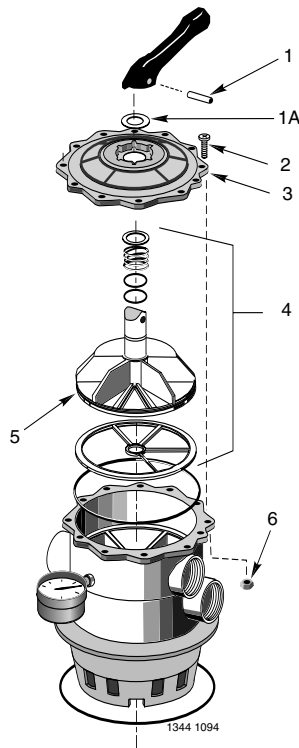

Fig. 11: Valve setting for winter storage. Stop pump before changing valve position.



**Fig. 12A: Valve Disassembly
(1-1/2" Multiport Valve)**



**Fig. 12B: Valve Disassembly
(2" Multiport Valve)**

2. Remove drain plug from filter.
3. Drain filter tank completely and replace drain cap (Figure 13, Page 10).
4. Cover with plastic or tarpaulin to protect from weather, but do not seal from air circulation.
5. Protect from freezing.

Startup for Winterized Equipment:

1. Remove any temporary weather protection placed around system for shut-down.
2. See "Startup", Page 7, for reactivation of the filter.
3. Inspect all electrical wiring to pump for damage or deterioration over the shutdown period. Have a qualified serviceman repair/replace wiring as needed. Inspect and tighten all watertight connections.
4. Open all valves in suction and return piping.
5. Remove any winterizing plugs in system.
6. Drain all winterizing chemicals (if used) from system; flush system.
7. Close all drain valves and replace all drain plugs in system (see Page 10).
8. Fill pool with water to proper level (see pool manufacturer's instructions).

MULTI-PORT VALVE SERVICE

▲WARNING Hazardous pressure. Stop pump and release all pressure from system before working on filter, valve, or clamp. Filter and valve design allows air to bleed off automatically in normal service. However, always be sure pressure is off system before working on filter, valve or clamp.

NOTICE: if Multi-Port valve is below pool water level, close suction and discharge valves before disassembly to prevent draining pool.

Handle Replacement:

1. Stop pump.
2. Place handle in 'FILTER' position.
3. Remove pin (Key 1, Figures 12A and 12B) to disconnect handle. If it cannot be removed by hand, use a hammer and center punch and lightly tap it out.
4. Remove handle; replace with a new one. Be sure new handle is in 'FILTER' position.
5. Replace pin.

Lid and Plug replacement:

1. **Remove Handle** (see 'Handle Replacement' above).
2. **Remove plug:**
 - A. Remove all screws and nuts (Key Nos. 2 and 6, Figures 12A and 12B).
 - B. Remove lid (Key No. 3) by pulling straight up while holding plug shaft (Key No. 5) down with thumb.
3. **Inspect Internal Parts:**
Inspect plug and gasket spring, O-Rings, and internal washers (Key No. 4). Replace if necessary.

4. Reassemble Valve:

- A. Replace plug gasket and shaft, mounting spring, washers, and O-Ring on plug shaft. Lubricate O-Ring with Amojel.
- B. Replace lid; match screw holes in lid and body.
- C. Press down on lid to allow screws to engage nuts; tighten each nut securely.
- D. Replace top washer (Key No. 1A) and handle, making sure indexing pin on plug shaft points in same direction as pointer on handle. Replace handle pin.
- E. Tighten all lid screws to 55 inch-lbs. (63.4 kg-cm) torque.

Valve Removal

▲WARNING Hazardous pressure. Stop pump and release all pressure from system before working on filter, valve, or clamp.

NOTICE: If multi-Port Valve is below pool water level, close suction and discharge valves before disassembly to prevent draining pool.

1. Disconnect piping from pump and pool.
2. Remove clamp.
3. Remove valve from filter top.
4. To reinstall valve, follow instructions, Figures 6 and 7, Page 7. BE SURE to follow clamp tightening instructions.

Drain Fitting Installation/Removal

NOTICE: If pool is above height of filter, first close valves in pump suction and return lines to prevent draining pool. If there are no shutoff valves installed, disconnect suction and return lines and raise ends above pool water level.

1. **Installation:** See Figure 13.
2. **To Drain Filter:**
 - A. Remove drain cap. Lateral tube should remain in place inside drain opening to prevent sand from draining out.
 - B. Open union coupling on backwash port of Multi-Port valve. This will allow air into filter and allow water to drain from filter tank.
 - C. Replace cap when tank is empty.
3. **Removing Sand From Filter:**
 - A. Remove both drain cap and slotted lateral tube (see Figure 13). Sand and water will drain from tank.
 - B. To completely flush filter tank of sand, remove top clamp and multiport valve and flush the inside of the tank with a hose.
 - C. Thoroughly clean sand from all parts and from tank drain opening before reassembling drain fitting.

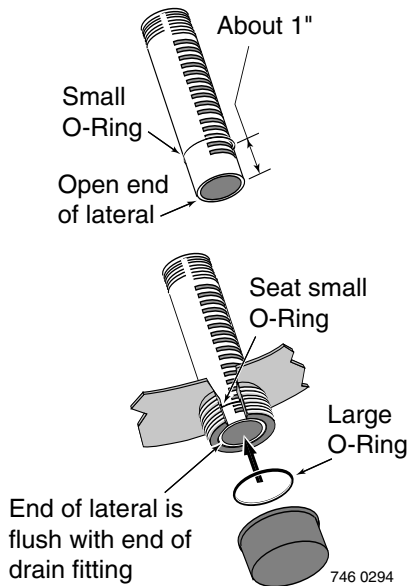
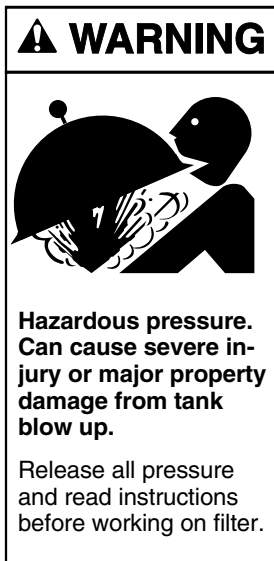

Figure 13: Drain Fitting Assembly.

This assembly allows water to drain without losing the sand out of the filter tank.

Make sure all surfaces are clean and free of sand. Don't cross thread cap; don't overtighten cap.

TROUBLESHOOTING GUIDE



1. Short Cycle between backwashes:

NOTICE: Time between backwashes will vary with each installation and between different areas of the country. Ask installer about normal backwash interval in your area. The following causes and remedies are for cycle times shorter than normal for your area.

- A. Flow rate too high or filter too small; consult dealer for system sizing recommendations.
- B. Water is chemically out of balance; consult pool serviceman.
- C. Excess dirt/dust in pool; vacuum pool directly to waste.
- D. Body oil/lotion build-up in filter; consult dealer for chemical filter cleaners and follow cleaner manufacturer's instructions.
- E. Filter inadequately backwashed. See instructions under "Startup/Operation", Page 7.
- F. Algae in pool. Consult pool professional about proper chemical maintenance.
- G. Residual chlorine level too low. Consult pool professional about proper chemical maintenance.
- H. Inspect filter sand for solidification caused by dust, calcium, skin oils, of suntan lotions.

2. Low Flow:

- A. Pipe blocked downstream from filter; remove obstruction.
- B. Piping too small; use larger pipe (consult dealer for sizing).
- C. Plugged pump; plugged hair and lint trap or skimmer basket. Clean thoroughly.

3. Pool Water Not Clear:

- A. Water is chemically out of balance; consult pool professional.
- B. Filter is too small; consult dealer about equipment sizing.
- C. Sand in pool means broken lateral. Drain both water and sand out of tank. Remove valve; follow procedure under "Filter Setup", Page 6, and instructions with new lateral to replace broken part.

⚠ WARNING To avoid severe injury or major property damage, follow instructions under 'Valve Installation', Figures 6 and 7, Page 7).

- 1. Follow valve removal procedure, Page 10.
- 2. Replace lateral according to instructions supplied with new lateral.
- 3. Reassemble filter according to instructions under "Filter Setup", Page 6.

REPAIR PARTS – TANKS
T-150BP-1, T-170BP-1,
T-200BP-1, T-240BP-1, T-
300BP-2

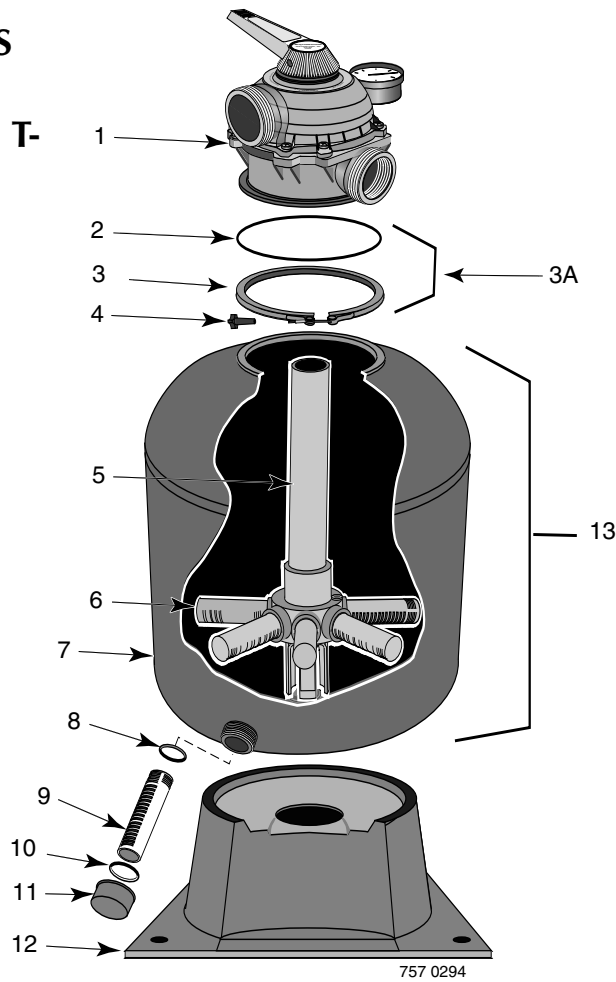

Key No.	Description	No. Used	Model				
			T-150BP-1	T-170BP-1	T-200BP-1	T-240BP-1	T-300BP-2
1	Multiport Valve, Top Mount (Includes Key Nos. 2 and 3)	1	WC112-148A	WC112-148A	WC112-148A	WC112-148A	14971-TM-22-L
2	O-Ring, Valve Flange	1	U9-369	U9-369	U9-369	U9-369	U9-369
3	V-Clamp w/Knob	1	WC119-87A	WC119-87A	WC119-87A	WC119-87A	WC119-87A
4	Clamp Knob	1	WC36-22	WC36-22	WC36-22	WC36-22	WC36-22
5	Collector Hub Assembly	1	24200-0110	WC137-516P	WC137-517P	WC137-519P	24205-0010
6	Lateral	8	24600-0003	24600-0003	24600-0003	24700-0075	21180-1530
7	Filter Tank	1	24200-1000	24201-1000	24203-1000	24204-1000	24205-1000
8	O-Ring, Lateral	1	U9-370	U9-370	U9-370	U9-370	U9-370
9	Drain Lateral	1	24201-0058	24201-0058	24201-0058	24201-0058	24201-0058
10	O-Ring, Drain Cap	1	U9-371	U9-371	U9-371	U9-371	U9-371
11	Drain Cap	1	14965-0025	14965-0025	14965-0025	14965-0025	14965-0025
12	Pedestal	1	23910-0005B	23910-0005B	23910-0005B	23900-0105B	23900-0205
13	Filter Tank Assembly	1	24200-0100	24201-0100	24203-0100	24204-0100	24205-0100
	• Union Coupling Package	3	C198-3M	C198-3M	C198-3M	C198-3M	–
	• Sand Loading Disc	1	24201-0043	24201-0043	24201-0043	24201-0043	24201-0063
	• Model & Instruction Label	1	32155-4115A	32155-4115B	32155-4115C	32155-4115D	90000-1329
	• Clamp Warning Decal	1	32165-4030	32165-4030	32165-4030	32165-4030	32165-4030
	• Information Decal	1	32155-4112	32155-4112	32155-4112	32155-4112	32155-4112

•Not Illustrated.

REPAIR PARTS – MULTI-PORT VALVES

WC112-148A

#14971-TM-22-L

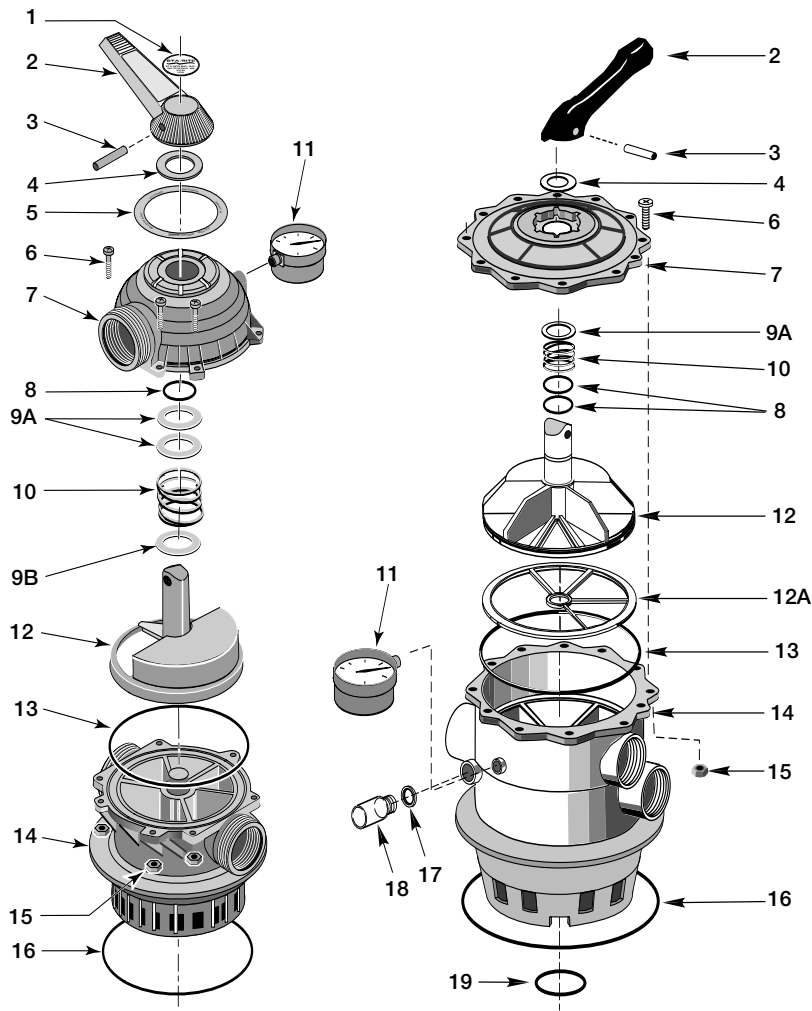

1343 1094

Key No.	Part Description	Qty.	WC112-148A	14971-TM-22-L
1	Valve Handle Decal	1	14965-0021	—
2	Handle	1	14962-0032	14971-SM10E1
3	Dowel Pin	1	35857-0021	14971-SM10E2
4	Washer	1	14965-0007	14971-SM10E3
5	Operating Instruction Decal	1	14965-0020	—
6	Screw	1	37337-3056(7)	14971-SM10E4(10)
7	Valve Cover	1	14965-0011	14971-SM20E6
8	O-Ring	1	35505-1228	14971-SM10E10
9A	Washer	2	14965-0007	14971-SM10E8
9B	Washer	1	14965-0007	—
10	Spring	1	14965-0006	14971-SM10E9
11	Pressure Gauge	1	15060-0000T	15060-0000T
12	Plug & Gasket Assembly	1	14965-0028	14971-SM20E11
12A	Gasket	1	—	14971-SM20E12
13	Cover O-Ring	1	35505-1275	14971-SM20E7
14	Valve Body Assembly	1	14965-0013	14971-SM20E13
15	Nut	1	35407-0071(7)	14971-SM10E14(10)
16	Tank Flange O-Ring	1	U9-369	U9-369
17	Sight Glass Gasket	1	—	14971-SM20E17
18	Sight Glass	1	—	14971-SM10E16
19	Stand Pipe O-Ring (EPDM)	1	—	35505-1243

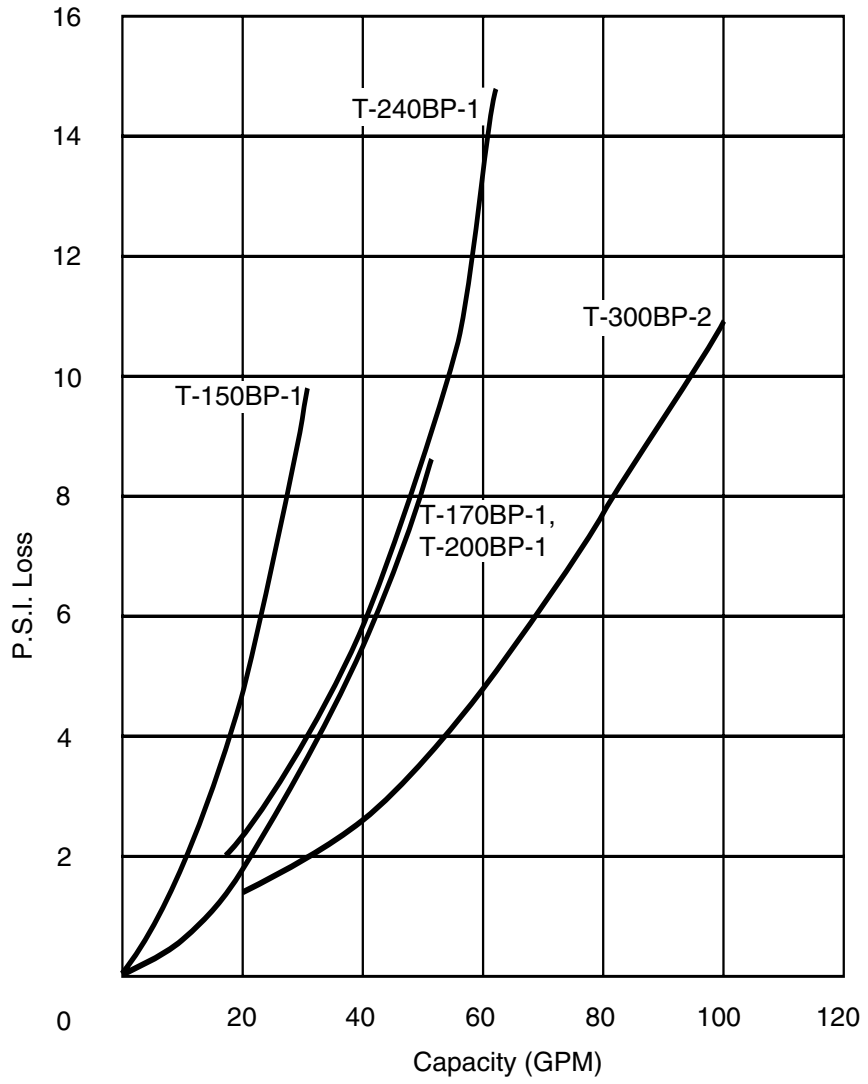

Figure 14 – Pressure Drop Curve - Filter Position

pool industry for any length of time.

ards of the swimming

7. Damage caused by water freezing inside the product.

8. Accidental damage, fire, acts of God, or other circumstances outside the control of Pentair Water Pool and Spa.

Product Family	Limited Warranty	Exceptions
Filters	1 year	
Aboveground Systems	1 year	
Pumps	1 year	
Heaters	2 years	MiniMax 75/100 - 1 year
Heat Pumps	2 years	Compressor Parts and Labor - 10 years
	Parts and Labor	Titanium Heat Exchanger - Lifetime
Lights	1 year	Bulbs - 90 days
Automation Equipment	1 year	SunTouch Solar - 3 years
Automatic Pool Cleaners	1 year	
Robotic Pool Cleaners	1 year	
	200 Cleaner Cycles	
Kreepy Krauly Cleaners	2 years	Suction Seal, Foot Pad, Wings Bumper Strap - 1 year
Kreepy Cruiser, Great White Cleaners	2 years	
PoolShark Cleaners	2 years	Foot Pad, Seal Flaps - 1 year
Maintenance Equipment/ Replacement Parts	90 days	
White Goods	1 year	
Chlorine Bromine Feeders	1 year	

This warranty extends to the original retail owner only, beginning on the date of installation and is not enforceable by any other party. Proof of purchase and/or date of installation will be required to execute a warranty claim. Original owner agrees to prepay all shipping charges to Pentair Water Pool and Spa.

Warranties by others: Some products incorporate components manufactured by other manufacturers. Some of these provide warranties in addition to the warranty provided herein. In all such cases a copy of that warranty will be provided with the product. To the extent protection provided under any such third party warranty exceeds the Limited Warranty provided herein, the Customer will have to look to that manufacturer for the additional protection.

(Continued On Other Side)

Please Detach Along Dotted Line and Mail This Section. Keep the Warranty for Your Records.

PRODUCT WARRANTY REGISTRATION CARD

Please promptly complete and return this postage paid card. In the unlikely event we must notify you of safety modifications to your product, under the Consumer Product Safety Act, this will allow us to communicate with you quickly. Incomplete or missing information such as your serial number will not be registered. **Your Limited Warranty is attached to this reply card.** Please detach it, review it thoroughly so you are familiar with the terms of your warranty coverage and keep in a safe place.

Product:

- FILTER PUMP HEATER HEAT PUMP LIGHT CONTROLS
 AUTO CLEANER AUTO FEEDER MAINT. EQUIPMENT WHITE GOODS

Brand/Model Name: _____

I purchased the Pentair product for use in: _____

- Inground Pool Inground Pool/Spa Combination Aboveground Pool Spa Only

My Serial Number is: _____
(If applicable)

1. Name: _____
(Please Print)

Street Address: _____

City: _____ State: _____ Zip: _____

Tel. No.: (____) _____ E-mail: _____

2. Date of Purchase/Installation: _____ New Replacement

Signature: _____ Date: _____

3. Where did you purchase your Pentair Product?

- Pool Builder Pool Store Pool Service Mail Order Internet Other

Company Name: _____

Location: _____

4. Please indicate how your pool and/or spa is presently equipped. (Check all that apply.)

- Heater (Approx. age _____) Heat Pump (Approx. age _____) Automatic Pool Cleaner
 Automatic Control System Fiber Optic Perimeter or Landscape Lights Automatic Chlorine Generator
 Underwater Color Changing Lights Chlorine Bromine In-Line (Plumbed) Feeder

5. Please indicate how important each of the following factors were in your buying decision:

- | | Very Important | Important | Somewhat Important | Not Important |
|---|--------------------------|--------------------------|--------------------------|--------------------------|
| Previous use of product | <input type="checkbox"/> | <input type="checkbox"/> | <input type="checkbox"/> | <input type="checkbox"/> |
| Sale price | <input type="checkbox"/> | <input type="checkbox"/> | <input type="checkbox"/> | <input type="checkbox"/> |
| Recommendation of others | <input type="checkbox"/> | <input type="checkbox"/> | <input type="checkbox"/> | <input type="checkbox"/> |
| Recommendation of salesperson | <input type="checkbox"/> | <input type="checkbox"/> | <input type="checkbox"/> | <input type="checkbox"/> |
| Reputation of store or builder | <input type="checkbox"/> | <input type="checkbox"/> | <input type="checkbox"/> | <input type="checkbox"/> |
| Reputation for customer service | <input type="checkbox"/> | <input type="checkbox"/> | <input type="checkbox"/> | <input type="checkbox"/> |
| Reputation for quality/durability | <input type="checkbox"/> | <input type="checkbox"/> | <input type="checkbox"/> | <input type="checkbox"/> |
| Style/appearance | <input type="checkbox"/> | <input type="checkbox"/> | <input type="checkbox"/> | <input type="checkbox"/> |
| Value for the price | <input type="checkbox"/> | <input type="checkbox"/> | <input type="checkbox"/> | <input type="checkbox"/> |
| Warranty | <input type="checkbox"/> | <input type="checkbox"/> | <input type="checkbox"/> | <input type="checkbox"/> |

6. This product replaces a: _____

(Brand)

Warranty Note: Automatic Cleaners purchased in the USA from entities outside the USA do not qualify for any USA programs including warranty, trade-in or rebate programs.

Thanks for taking the time to fill out this questionnaire. Your answers will help us to better serve you in the future.



FOLD IN HALF AND SEAL FOR MAILING



PENTAIR WATER POOL AND SPA
PO BOX 101480
FT LAUDERDALE FL 33310-9947

POSTAGE WILL BE PAID BY ADDRESSEE

BUSINESS REPLY MAIL
FIRST-CLASS MAIL PERMIT 29 FT LAUDERDALE FL

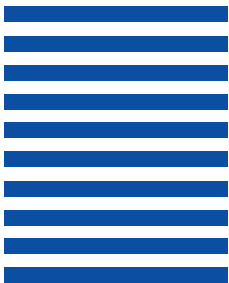

NO POSTAGE
NECESSARY
IF MAILED
IN THE
UNITED STATES



LIMITED WARRANTY

(Continued From Other Side)

Warranty Obligations of Pentair Water Pool and Spa

Should a defect in workmanship and/or material in any item covered by this warranty become evident during the term of the warranty, then upon the consumer following the procedures set forth below, Pentair Water will, at its option, repair or replace such item or part at its own cost and expense.

Pentair Water is not, however, responsible under this warranty for any cost of shipping or transportation of the equipment or parts thereof to or from the Technical Service Department. Also, Pentair Water is not liable for any loss of time, inconvenience, incidental expenses such as telephone calls, labor or material charges incurred in connection with the removal or replacement of the equipment, or any other incidental or consequential damages.

This warranty is void if the product is repaired or altered in any way by any persons, agents or representatives other than those authorized by Pentair. Expendables including, but not limited to refrigerant, recovery of refrigerant, or transportation for components are not covered under this limited warranty. Reasonable vehicle trip and evaluation charges may be assessed by the service representative. Pentair, at its sole discretion, reserves the right to provide a replacement product or part, of equal value, in lieu of repair.

PLEASE NOTE: Some states do not allow the exclusion or limitation of incidental or consequential damages, so the above limitation or exclusion may not apply to you.

No Other Warranties

To the maximum extent permitted by applicable law, Pentair Water disclaims all other warranties, either expressed or implied, including, but not limited to, implied warranties of merchantability and fitness for a particular purpose, with regard to the Product(s), Part(s) and/or any accompanying written materials.

Procedure for Obtaining Performance

In order to obtain the benefits of this warranty, the consumer who made the original retail purchase must contact the Pentair Water Technical Service Department as soon as possible after discovery of the defect, but in no event later than the expiration date of the warranty period provided in this warranty. Upon receipt of this communication, Pentair Water will promptly notify the customer of the address to which the defective item may be shipped. The customer shall then ship the item, freight prepaid, to the address indicated, together with a "RETURN GOODS AUTHORIZATION" form obtained from Technical Service and a brief description of the problems encountered. Unauthorized returns will not be accepted. Freight must be prepaid by customer.

Warranties or Representations by Others

No dealer or other person has any authority to make any warranties or representation concerning Pentair Water or its products. Accordingly, Pentair Water Pool and Spa is not responsible for any such warranties or representations.

Other Rights

This warranty gives you specific legal rights and you may also have other rights, which vary from state to state.

Sole Warranty

Supersedes all previous publications.

PENTAIR WATER POOL AND SPA, INC.

1620 Hawkins Ave. Sanford, NC 27330
10951 W. Los Angeles Ave. Moorpark, CA 93021
Phone: 800-831-7133 Fax: 800-284-4151